

Instructions-Parts



Python[®] XL Chemical Injection Pump

3A3948H

EN

**Pneumatic pump for injecting chemicals at well sites. Not for use with sour gas.
For professional use only.**

Not approved for use in European explosive atmosphere locations.

See page 3 for model information, including maximum working pressures.



Important Safety Instructions

Read all warnings and instructions in this manual.
Save all instructions.

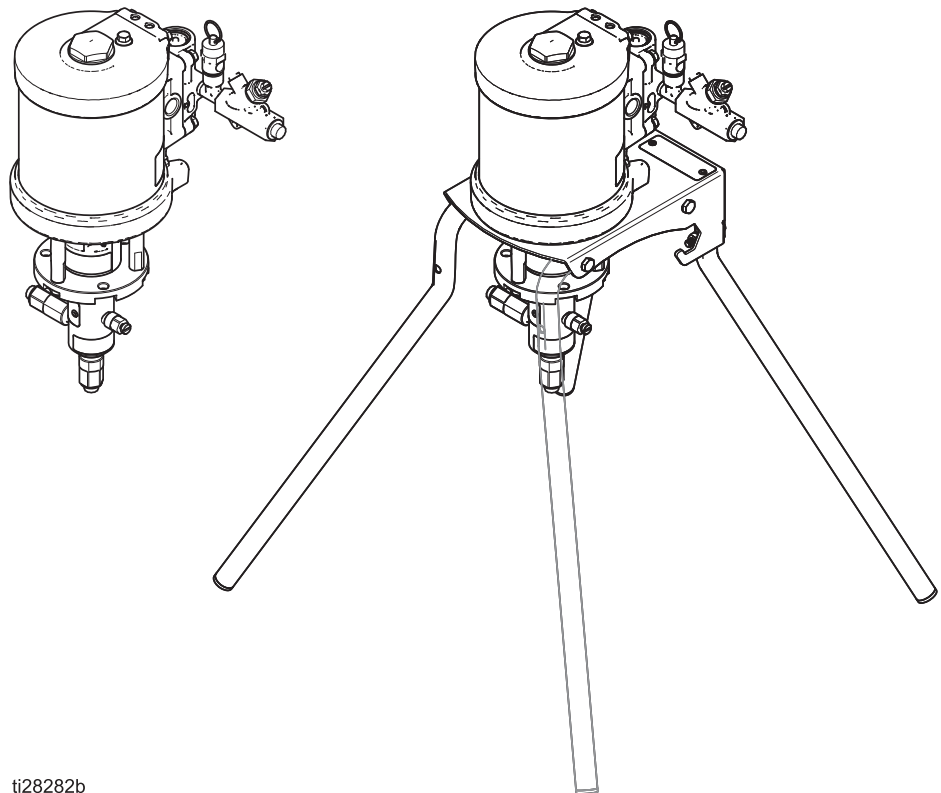

ti28282b



PROVEN QUALITY. LEADING TECHNOLOGY.

Contents

| | | | |
|---------------------------------------------------------------|-----------|--------------------------------------|-----------|
| Models | 3 | Performance Charts | 43 |
| Configuration Number Matrix | 4 | 2.5 in. Motors | 43 |
| Pump Configuration | 4 | 3.5 in. Motors | 46 |
| Lower Configuration | 4 | 4.5 in. Motors | 49 |
| Warnings | 5 | Air/Gas Consumption | 52 |
| Installation | 7 | Technical Data | 53 |
| Grounding | 7 | Graco Standard Warranty | 54 |
| Required Accessories | 7 | | |
| Flush Before Using Equipment | 7 | | |
| Typical Installation | 8 | | |
| Mount the Pump and Connect Chemical Supply | 8 | | |
| Connect Pneumatic Supply | 9 | | |
| Route Exhaust to Remote Location | 9 | | |
| Connect Chemical Outlet | 9 | | |
| Operation | 13 | | |
| Pressure Relief Procedure | 13 | | |
| Flush the Equipment | 13 | | |
| Prime the Pump | 14 | | |
| Calibrate Chemical Dosage | 14 | | |
| Maintenance | 18 | | |
| Preventive Maintenance Schedule | 18 | | |
| Tighten Threaded Connections | 18 | | |
| Tighten Packings | 18 | | |
| Storage | 18 | | |
| Troubleshooting | 19 | | |
| Repair | 20 | | |
| Pump | 20 | | |
| Check Valves | 23 | | |
| Pneumatic Valve | 25 | | |
| Replace Pilot Valves | 27 | | |
| Disconnect the Pneumatic Motor | 28 | | |
| Reconnect the Pneumatic Motor | 28 | | |
| Repair Pneumatic Motor | 29 | | |
| Parts | 32 | | |
| Python XL Pneumatic Pump | 32 | | |
| Pneumatic Motor Parts | 36 | | |
| Pneumatic Valve Parts | 38 | | |
| Kits and Accessories | 40 | | |
| Dimensions | 41 | | |
| Python XL Pump Dimensions | 41 | | |
| Wall Bracket Mounting Hole Diagram, 2.5 in. & 3.5 in. | 42 | | |
| Wall Bracket Mounting Hole Diagram, 4.5 in. | 42 | | |

Models

| Plunger Size | Pneumatic Motor Size | Maximum Working Pressure psi (MPa, bar) | Maximum Pneumatic Inlet Pressure psi (MPa, bar) |
|--------------|----------------------|--------------------------------------------|----------------------------------------------------|
| 1/8 in. | 2.5 in. | 12,000 (82.7, 827.4) | 30.0 (0.2, 2.1) |
| 3/16 in. | | 12,000 (82.7, 827.4) | 67.5 (0.5, 4.7) |
| 1/4 in. | | 10,000 (68.9, 689.5) | 100 (0.69, 6.9) |
| 3/8 in. | | 4444 (27.6, 275.8) | |
| 1/2 in. | | 2500 (17.2, 172.4) | |
| 5/8 in. | | 1600 (11.0, 110.3) | |
| 3/4 in. | | 1111 (7.7, 76.6) | |
| 1/4 in. | 3.5 in. | 12,000 (82.7, 827) | 61.2 (0.4, 4.2) |
| 3/8 in. | | 8700 (60.0, 599.8) | 100 (0.69, 6.9) |
| 1/2 in. | | 4900 (33.8, 337.8) | |
| 5/8 in. | | 3136 (21.6, 216.2) | |
| 3/4 in. | | 2180 (15.0, 150.3) | |
| 1/4 in. | 4.5 in. | 12,000 (82.7, 822.4) | 37.0 (0.3, 2.6) |
| 3/8 in. | | 10,000 (68.9, 689.5) | 69.4 (0.5, 4.8) |
| 1/2 in. | | 8100 (55.8, 558.5) | 100 (0.69, 6.9) |
| 5/8 in. | | 5200 (35.9, 358.5) | |
| 3/4 in. | | 3600 (24.8, 248.2) | |

NOTE: See the **Configuration Number Matrix**, page 4, to find the plunger and pneumatic motor size for your unit.

Configuration Number Matrix

Check the identification plate (ID) for the 12-digit Configuration Number of your pump. Use the following matrix to define the components of your pump.

NOTE: Not all combinations are possible.

Sample Configuration Number: PCI-350-25S-XA-0

| PCI | 350 | 25 | S | X | A | 0 |
|------------------------------------|-------------------------|--------------|----------------|------------------|---------------|-----------|
| Pneumatic Chemical Injection | Pneumatic Motor Size | Plunger Size | Pressure Range | Plunger Material | Seal Material | Qualifier |

Pump Configuration

| Pneumatic Motor Size | | Plunger Size | | Outlet Connection Type | | Plunger Material | | Seal Material | | Qualifier | |
|----------------------|-----------|--------------|-------------------|------------------------|----------------|------------------|---------|---------------|--------|-----------|------|
| 250 | 2 1/2 in. | 13 | 1/8 in. diameter | S | 1/4 in. NPT(F) | X | Chromex | A | FKM | 0 | None |
| 350 | 3 1/2 in. | 19 | 3/16 in. diameter | H | HiP HF4 | C | Ceramic | B | FKMETP | | |
| 450 | 4 1/2 in. | 25 | 1/4 in. diameter | | | | | C | HNBR | | |
| | | 38 | 3/8 in. diameter | | | | | D | FFKM | | |
| | | 50 | 1/2 in. diameter | | | | | E | TFE/P | | |
| | | 63 | 5/8 in. diameter | | | | | | | | |
| | | 75 | 3/4 in. diameter | | | | | | | | |

Key Points









- All pumps feature 1/4 in. NPT(F) inlet connections.
- Kit B32240 can be used to convert an HF4 outlet connection to a 1/4 in. NPT(F) for applications at or under 10,000 psi.

Lower Configuration

| Plunger Size | | Outlet Connection Type | | Plunger Material | | Seal Material | |
|--------------|-------------------|------------------------|----------------|------------------|---------|---------------|--------|
| 13 | 1/8 in. diameter | S | 1/4 in. NPT(F) | X | Chromex | A | FKM |
| 19 | 3/16 in. diameter | H | HiP HF4 | C | Ceramic | B | FKMETP |
| 25 | 1/4 in. diameter | | | | | C | HNBR |
| 38 | 3/8 in. diameter | | | | | D | FFKM |
| 50 | 1/2 in. diameter | | | | | E | TFE/P |
| 63 | 5/8 in. diameter | | | | | | |
| 75 | 3/4 in. diameter | | | | | | |

Warnings

The following warnings are for the setup, use, grounding, maintenance, and repair of this equipment. The exclamation point symbol alerts you to a general warning and the hazard symbols refer to procedure-specific risks. When these symbols appear in the body of this manual or on warning labels, refer back to these Warnings. Product-specific hazard symbols and warnings not covered in this section may appear throughout the body of this manual where applicable.

|  <h1 style="margin: 0;">WARNING</h1> | |
|------------------------------------------------------------------------------------------------------------------------------------------------------------------------------------------------------------------------------------------------------------------------------------------------------------------------------------------------------------------------------------------------------------------------------------|--------------------------------------------------------------------------------------------------------------------------------------------------------------------------------------------------------------------------------------------------------------------------------------------------------------------------------------------------------------------------------------------------------------------------------------------------------------------------------------------------------------------------------------------------------------------------------------------------------------------------------------------------------------------------------------------------------------------------------------------------------------------------------------------------------------------------------------------------------------------------------------------------------------------|
|   | <p>FIRE AND EXPLOSION HAZARD</p> <p>When flammable fluids are present in the work area be aware that flammable fumes can ignite or explode. To help prevent fire and explosion:</p> <ul style="list-style-type: none"> • Use equipment only in well ventilated area. • Eliminate all ignition sources, such as cigarettes and portable electric lamps. • Ground all equipment in the work area. • Keep work area free of debris, including rags and spilled or open containers of solvent. • Do not plug or unplug power cords or turn lights on or off when flammable fumes are present. • Use only grounded hoses. • Stop operation immediately if static sparking occurs or you feel a shock. Do not use equipment until you identify and correct the problem. • Keep a working fire extinguisher in the work area. |
|      | <p>SKIN INJECTION HAZARD</p> <p>High-pressure fluid from dispensing device, hose leaks, or ruptured components will pierce skin. This may look like just a cut, but it is a serious injury that can result in amputation. Get immediate surgical treatment.</p> <ul style="list-style-type: none"> • Do not put your hand over the fluid outlet. • Do not stop or deflect leaks with your hand, body, glove, or rag. • Follow the Pressure Relief Procedure when you stop dispensing and before cleaning, checking, or servicing equipment. • Tighten all fluid connections before operating the equipment. • Check hoses and couplings daily. Replace worn or damaged parts immediately. |
|  | <p>TOXIC FLUID OR FUMES HAZARD</p> <p>Toxic fluids or fumes can cause serious injury or death if splashed in the eyes or on skin, inhaled, or swallowed.</p> <ul style="list-style-type: none"> • Read Safety Data Sheet (SDS) to know the specific hazards of the fluids you are using. • Store hazardous fluid in approved containers, and dispose of it according to applicable guidelines. |

! WARNING



PERSONAL PROTECTIVE EQUIPMENT

Wear appropriate protective equipment when in the work area to help prevent serious injury, including eye injury, hearing loss, inhalation of toxic fumes, and burns. Protective equipment includes but is not limited to:

- Protective eyewear, and hearing protection.
- Respirators, protective clothing, and gloves as recommended by the fluid and solvent manufacturer.





EQUIPMENT MISUSE HAZARD

Misuse can cause death or serious injury.

- Do not operate the unit when fatigued or under the influence of drugs or alcohol.
- Do not exceed the maximum working pressure or temperature rating of the lowest rated system component. See **Technical Data** in all equipment manuals.
- Use fluids and solvents that are compatible with equipment wetted parts. See **Technical Data** in all equipment manuals. Read fluid and solvent manufacturer's warnings. For complete information about your material, request Safety Data Sheet (SDS) from distributor or retailer.
- Turn off all equipment and follow the **Pressure Relief Procedure** when equipment is not in use.
- Check equipment regularly. Repair or replace worn or damaged parts immediately with genuine manufacturer's replacement parts only.
- Do not alter or modify equipment. Alterations or modifications may void agency approvals and create safety hazards.
- Make sure all equipment is rated and approved for the environment in which you are using it.
- Use equipment only for its intended purpose. Call your distributor for information.
- Route hoses and cables away from traffic areas, sharp edges, moving parts, and hot surfaces.
- Do not kink or over bend hoses or use hoses to pull equipment.
- Keep children and animals away from work area.
- Comply with all applicable safety regulations.



Installation

| | | | | |
|-----------------------------------------------------------------------------------|-----------------------------------------------------------------------------------|-----------------------------------------------------------------------------------|--|--|
|  |  |  | | |
|-----------------------------------------------------------------------------------|-----------------------------------------------------------------------------------|-----------------------------------------------------------------------------------|--|--|

If using a flammable gas to drive the motor, to reduce the risk of fire or explosion, route the exhaust away from all sources of ignition. See **Route Exhaust to Remote Location** on page 9.

NOTE: 3.5% of the exhaust is not recoverable, and will vent to atmosphere at the pump.

To reduce the risk of injury from ejected ice, do not operate the motor without a plumbed exhaust line or muffler installed.

Installation must comply with all local codes and regulations.

Grounding

| | | | | |
|------------------------------------------------------------------------------------|------------------------------------------------------------------------------------|------------------------------------------------------------------------------------|--|--|
|  |  |  | | |
|------------------------------------------------------------------------------------|------------------------------------------------------------------------------------|------------------------------------------------------------------------------------|--|--|

The equipment must be grounded to reduce the risk of static sparking. Static sparking can cause fumes to ignite or explode. Grounding provides an escape wire for the electric current.

Pump: ground through electrically conductive pneumatic and fluid lines.

Pneumatic and fluid lines: use only electrically conductive lines.

Air compressor: follow manufacturer's recommendations.

Fluid supply container: follow local code.

Required Accessories

Install the following required accessories in the order shown in FIG. 1, using adapters as necessary. See **Kits and Accessories** starting on page 40.

Pneumatic Line

- **Bleed-type master pneumatic valve (D):** required in your system to relieve air/gas trapped between it and the pneumatic motor when the valve is closed.
 - Be sure the valve is easily accessible from the pump and located downstream from the pneumatic regulator.
- **Pump pneumatic regulator (E):** to control pump speed and outlet pressure. Locate it close to the pump.
- **Pneumatic line filter (C):** removes harmful dirt and moisture from compressed air/gas supply.
- **Second bleed-type pneumatic valve (pneumatic shutoff valve) (B):** isolates pneumatic line accessories for servicing. Locate upstream from all other pneumatic line accessories.

Fluid Line

- **Fluid filter (Y-Strainer) (included in G):** with a 60 mesh (250 micron) stainless steel element to filter particles from the fluid before it reaches the pump.
- **Fluid shutoff valve (H):** shuts off fluid flow.
- **Pressure relief valve (J):** overload protection.

Flush Before Using Equipment

The equipment was tested with lightweight oil, which is left in the fluid passages to protect parts. To avoid contaminating your fluid with oil, flush the equipment with a compatible solvent before using the equipment. See **Flush the Equipment**, page 13.

Typical Installation

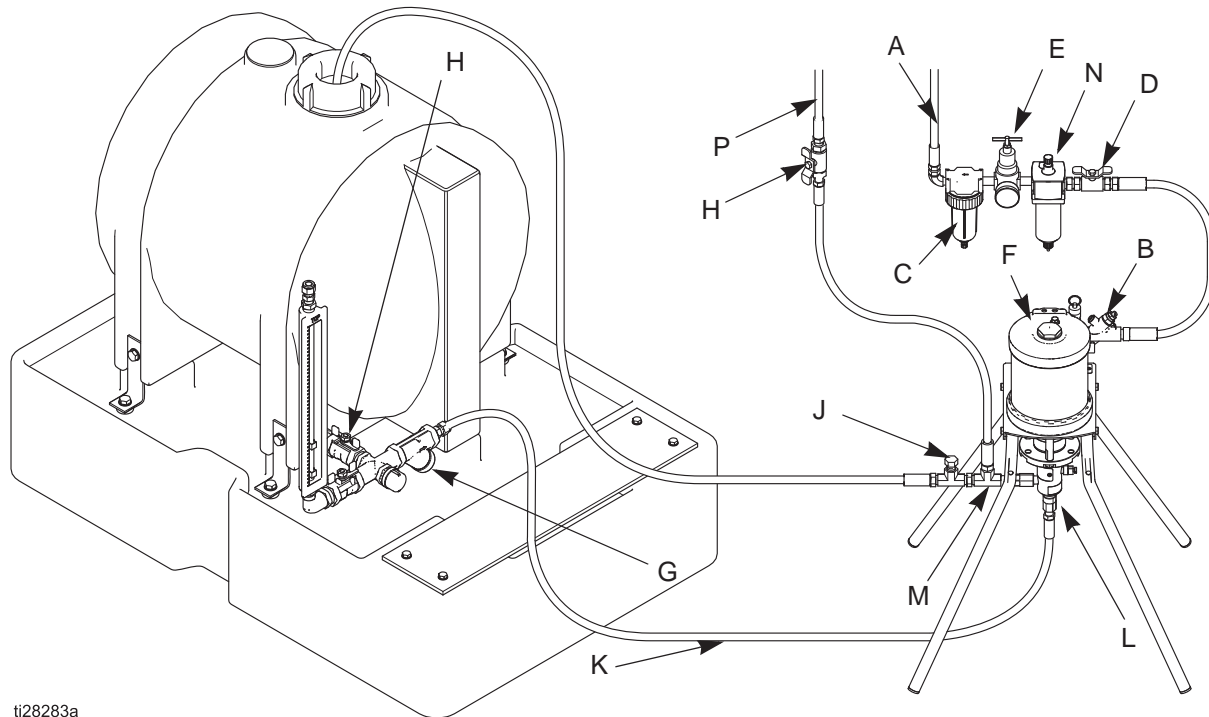

ti28283a

FIG. 1: Typical Installation

FIG. 1 is an example of an installation with a Python chemical injection pump. Your installation may differ from what is shown here. (See **Required Accessories**, page 7.) The Python pump (F) is the only component in FIG. 1 supplied by Graco. All other components are supplied by customer.

Key:

- A Main Pneumatic Supply Line
- B Pneumatic Needle Valve
- C Pneumatic Filter
- D Bleed-type Master Pneumatic Valve
- E Pneumatic Pressure Regulator
- F Pump
- G Manifold Assembly (includes y-strainer and fluid shutoff valve (H))
- H Fluid Shutoff Valve (inlet & outlet)
- J Fluid Pressure Relief Valve
- K Fluid Inlet Line
- L Inlet Port
- M Outlet Port
- N Pneumatic Lubricator
- P Fluid Outlet Line

Mount the Pump and Connect Chemical Supply



The pump can be used with supplied legs, or the pump stand can be bolted to a wall or skid by the attached bracket.

If you have an application, or mounting configuration, that requires installation in a manner different than depicted in FIG. 1, please contact your Graco distributor for assistance.

NOTE: A y-strainer (G) or chemical filter is required before the pump inlet. This will keep any debris from the tank from reaching the pump seals. Fluid filters are available from Graco. See **Kits and Accessories** on page 40.

1. Mount the pump (F) and connect the fluid inlet line (K).

Connect Pneumatic Supply

1. Install the pneumatic regulator (E) and gauge to control the inlet pressure. See **Models** on page 3 for your model's maximum pneumatic pressure.

NOTE: If less than 100 psi supply pressure is used, the pump's maximum output pressure will be decreased proportionally. See **Minimum Pneumatic Pressures by Fluid Plunger Size and Outlet Pressures** on page 10. Minimum Pneumatic Pressure can be found by first finding the table that corresponds to the plunger size. Next, using the column that corresponds to the pneumatic motor size, find the row equal to or slightly greater than the outlet pressure of the pump. The value is the Minimum Pneumatic Pressure required to achieve the fluid outlet pressure.

2. Install a pneumatic line filter (C) to keep debris from affecting pump performance and to increase pump life.

NOTE: Keep the needle valve knob closed at this point to keep the pump from operating without fluid, which minimizes seal wear.

3. Attach a pneumatic line to the 1/4 in. female NPT port (116) on the needle valve.

Route Exhaust to Remote Location

Replace the 3/8 in. npt muffler (215) with a pneumatic line to route exhaust to a remote location.

NOTICE

Due to the operational design of the pneumatic valve, 3.5% of the exhaust is not recoverable, and will vent to atmosphere.

Connect Chemical Outlet

1. Connect a 1/4 npt(f) fluid line from the outlet check valve (M) to the injection point.

NOTE: On "H" outlet connection configurations (PCI-xxx-xxH-xx-x), the 1/4 npt(f) fitting is replaced with an HiP HF4 fitting.

2. Install a fluid pressure relief valve (J) on the outlet side of the pump.

NOTE: A pressure relief valve is available from Graco and can be connected back to the tank or directly to the inlet side of the pump. See **Kits and Accessories** on page 40.



In the event of an injection line blockage, to reduce the risk of skin injection and damage to the pump, ensure the pressure relief valve is set at or below the maximum working pressure of the pump.

3. Set the pressure relief valve at or below the maximum working pressure of the pump.
4. Connect a 10-32 UNF fluid outlet from the prime/bleed valve (21) to the fluid source or waste reservoir.

NOTE: On "H" outlet connection configurations (PCI-xxx-xxH-xx-x), the 10-32 fitting is replaced with a 1/16 in. NPT(F) fitting.

Minimum Pneumatic Pressures by Fluid Plunger Size and Outlet Pressures

Actual running pressure must be set in field to avoid stalling. See **Performance Charts**, starting on page 43, for maximum flows at any given pressure.

| 250 Pneumatic Motor Minimum Gas Pressure psi (MPa, bar) | | | | | | | |
|---------------------------------------------------------|---------------------------|----------------------------|---------------------------|---------------------------|---------------------------|---------------------------|---------------------------|
| Outlet Pressure psi (MPa, bar) | 1/8 Inch Fluid Plunger | 3/16 Inch Fluid Plunger | 1/4 Inch Fluid Plunger | 3/8 Inch Fluid Plunger | 1/2 Inch Fluid Plunger | 5/8 Inch Fluid Plunger | 3/4 Inch Fluid Plunger |
| 0 (0, 0) | 15.0 (0.1, 1.0) | 15.0 (0.1, 1.0) | 15.0 (0.1, 1.0) | 15.0 (0.1, 1.0) | 15.0 (0.1, 1.0) | 15.0 (0.1, 1.0) | 15.0 (0.1, 1.0) |
| 250 (1.7, 17.2) | 15.0 (0.1, 1.0) | 15.0 (0.1, 1.0) | 15.0 (0.1, 1.0) | 15.0 (0.1, 1.0) | 15.0 (0.1, 1.0) | 15.6 (0.1, 1.1) | 22.5 (0.2, 1.6) |
| 500 (3.4, 34.5) | 15.0 (0.1, 1.0) | 15.0 (0.1, 1.0) | 15.0 (0.1, 1.0) | 15.0 (0.1, 1.0) | 20.0 (0.1, 1.4) | 31.3 (0.2, 2.2) | 45.0 (0.3, 3.1) |
| 750 (5.2, 51.7) | 15.0 (0.1, 1.0) | 15.0 (0.1, 1.0) | 15.0 (0.1, 1.0) | 16.9 (0.1, 1.2) | 30.0 (0.2, 2.1) | 46.9 (0.3, 3.2) | 67.5 (0.5, 4.7) |
| 1000 (6.9, 68.9) | 15.0 (0.1, 1.0) | 15.0 (0.1, 1.0) | 15.0 (0.1, 1.0) | 22.5 (0.2, 1.6) | 40.0 (0.3, 2.8) | 62.5 (0.4, 4.3) | 90.0 (0.6, 6.2) |
| 1111 (7.7, 76.6) | 15.0 (0.1, 1.0) | 15.0 (0.1, 1.0) | 15.0 (0.1, 1.0) | 25.0 (0.2, 1.7) | 44.4 (0.3, 3.1) | 69.4 (0.5, 4.8) | 100.0 (0.7, 6.9) |
| 1500 (10.3, 103.4) | 15.0 (0.1, 1.0) | 15.0 (0.1, 1.0) | 15.0 (0.1, 1.0) | 33.8 (0.2, 2.3) | 60.0 (0.4, 4.1) | 93.8 (0.6, 6.5) | |
| 1600 (11.0, 110.3) | 15.0 (0.1, 1.0) | 15.0 (0.1, 1.0) | 16.0 (0.1, 1.1) | 36.0 (0.2, 2.5) | 64.0 (0.4, 4.4) | 100.0 (0.7, 6.9) | |
| 2000 (13.8, 137.9) | 15.0 (0.1, 1.0) | 15.0 (0.1, 1.0) | 20.0 (0.1, 1.4) | 45.0 (0.3, 3.1) | 80.0 (0.6, 5.5) | | |
| 2250 (15.5, 155.1) | 15.0 (0.1, 1.0) | 15.0 (0.1, 1.0) | 22.5 (0.2, 1.6) | 50.6 (0.3, 3.5) | 90.0 (0.6, 6.2) | | |
| 2500 (17.2, 172.4) | 15.0 (0.1, 1.0) | 15.0 (0.1, 1.0) | 25.0 (0.2, 1.7) | 56.3 (0.4, 3.9) | 100.0 (0.7, 6.9) | | |
| 2750 (19.0, 189.6) | 15.0 (0.1, 1.0) | 15.5 (0.1, 1.1) | 27.5 (0.2, 1.9) | 61.9 (0.4, 4.3) | | | |
| 3000 (20.7, 206.8) | 15.0 (0.1, 1.0) | 16.9 (0.1, 1.2) | 30.0 (0.2, 2.1) | 67.5 (0.5, 4.7) | | | |
| 3250 (22.4, 224.1) | 15.0 (0.1, 1.0) | 18.3 (0.1, 1.3) | 32.5 (0.2, 2.2) | 73.1 (0.5, 5.0) | | | |
| 3500 (24.1, 241.3) | 15.0 (0.1, 1.0) | 19.7 (0.1, 1.4) | 35.0 (0.2, 2.4) | 78.8 (0.5, 5.4) | | | |
| 3750 (25.9, 258.6) | 15.0 (0.1, 1.0) | 21.1 (0.1, 1.5) | 37.5 (0.3, 2.6) | 84.4 (0.6, 5.8) | | | |
| 4000 (27.6, 275.8) | 15.0 (0.1, 1.0) | 22.5 (0.2, 1.6) | 40.0 (0.3, 2.8) | 90.0 (0.6, 6.2) | | | |
| 4250 (29.3, 293.0) | 15.0 (0.1, 1.0) | 23.9 (0.2, 1.6) | 42.5 (0.3, 2.9) | 95.6 (0.7, 6.6) | | | |
| 4444 (30.6, 306.4) | 15.0 (0.1, 1.0) | 25.0 (0.2, 1.7) | 44.4 (0.3, 3.1) | 100.0 (0.7, 6.9) | | | |
| 4750 (32.8, 327.5) | 15.0 (0.1, 1.0) | 26.7 (0.2, 1.8) | 47.5 (0.3, 3.3) | | | | |
| 5000 (34.5, 344.7) | 15.0 (0.1, 1.0) | 28.1 (0.2, 1.9) | 50.0 (0.3, 3.4) | | | | |
| 5250 (36.2, 362.0) | 15.0 (0.1, 1.0) | 29.5 (0.2, 2.0) | 52.5 (0.4, 3.6) | | | | |
| 5500 (37.9, 379.2) | 15.0 (0.1, 1.0) | 30.9 (0.2, 2.1) | 55.0 (0.4, 3.8) | | | | |
| 5750 (39.6, 396.4) | 15.0 (0.1, 1.0) | 32.3 (0.2, 2.2) | 57.5 (0.4, 4.0) | | | | |
| 6000 (41.4, 413.7) | 15.0 (0.1, 1.0) | 33.8 (0.2, 2.3) | 60.0 (0.4, 4.1) | | | | |
| 6250 (43.1, 430.9) | 15.6 (0.1, 1.1) | 35.2 (0.2, 2.4) | 62.5 (0.4, 4.3) | | | | |
| 6500 (44.8, 448.2) | 16.3 (0.1, 1.1) | 36.6 (0.3, 2.5) | 65.0 (0.4, 4.5) | | | | |
| 6750 (46.5, 465.4) | 16.9 (0.1, 1.2) | 38.0 (0.3, 2.6) | 67.5 (0.5, 4.7) | | | | |
| 7000 (48.3, 482.6) | 17.5 (0.1, 1.2) | 39.4 (0.3, 2.7) | 70.0 (0.5, 4.8) | | | | |
| 7250 (50.0, 499.9) | 18.1 (0.1, 1.2) | 40.8 (0.3, 2.8) | 72.5 (0.5, 5.0) | | | | |
| 7500 (51.7, 517.1) | 18.8 (0.1, 1.3) | 42.2 (0.3, 2.9) | 75.0 (0.5, 5.2) | | | | |
| 7750 (53.4, 534.3) | 19.4 (0.1, 1.3) | 43.6 (0.3, 3.0) | 77.5 (0.5, 5.3) | | | | |
| 8000 (55.2, 551.6) | 20.0 (0.1, 1.4) | 45.0 (0.3, 3.1) | 80.0 (0.6, 5.5) | | | | |
| 8250 (56.9, 568.8) | 20.6 (0.1, 1.4) | 46.4 (0.3, 3.2) | 82.5 (0.6, 5.7) | | | | |
| 8500 (58.6, 586.1) | 21.3 (0.1, 1.5) | 47.8 (0.3, 3.3) | 85.0 (0.6, 5.9) | | | | |
| 8750 (60.3, 603.3) | 21.9 (0.2, 1.5) | 49.2 (0.3, 3.4) | 87.5 (0.6, 6.0) | | | | |
| 9000 (62.1, 620.5) | 22.5 (0.2, 1.6) | 50.6 (0.3, 3.5) | 90.0 (0.6, 6.2) | | | | |
| 9250 (63.8, 637.8) | 23.1 (0.2, 1.6) | 52.0 (0.4, 3.6) | 92.5 (0.6, 6.4) | | | | |
| 9500 (65.5, 655.0) | 23.8 (0.2, 1.6) | 53.4 (0.4, 3.7) | 95.0 (0.7, 6.6) | | | | |
| 9700 (66.9, 668.8) | 24.3 (0.2, 1.7) | 54.6 (0.4, 3.8) | 97.0 (0.7, 6.7) | | | | |
| 10000 (68.9, 689.5) | 25.0 (0.2, 1.7) | 56.3 (0.4, 3.9) | 100.0 (0.7, 6.9) | | | | |
| 10250 (70.7, 706.7) | 25.6 (0.2, 1.8) | 57.7 (0.4, 4.0) | | | | | |
| 10500 (72.4, 723.9) | 26.3 (0.2, 1.8) | 59.1 (0.4, 4.1) | | | | | |
| 10750 (74.1, 741.2) | 26.9 (0.2, 1.9) | 60.5 (0.4, 4.2) | | | | | |
| 11000 (75.8, 758.4) | 27.5 (0.2, 1.9) | 61.9 (0.4, 4.3) | | | | | |
| 11250 (77.6, 775.7) | 28.1 (0.2, 1.9) | 63.3 (0.4, 4.4) | | | | | |
| 11500 (79.3, 792.9) | 28.8 (0.2, 2.0) | 64.7 (0.4, 4.5) | | | | | |
| 11750 (81.0, 810.1) | 29.4 (0.2, 2.0) | 66.1 (0.5, 4.6) | | | | | |
| 12000 (82.7, 827.4) | 30.0 (0.2, 2.1) | 67.5 (0.5, 4.7) | | | | | |

For applications where the exhaust is ported to a pressurized location, compute the difference between the inlet and outlet pressures to get the pneumatic pressure to be used in the above tables. Minimum pressure differential is 15 psi (0.1 Mpa, 1.0 bar).

NOTE: Regardless of exhaust pressure, maximum inlet pressure is 100 psi (0.7 MPa, 6.9 bar), unless otherwise noted in **Models** on page 3.

| 350 Pneumatic Motor Minimum Gas Pressure psi (MPa, bar) | | | | | |
|----------------------------------------------------------------|-------------------------------|-------------------------------|-------------------------------|-------------------------------|-------------------------------|
| Outlet Pressure psi (MPa, bar) | 1/4 Inch Fluid Plunger | 3/8 Inch Fluid Plunger | 1/2 Inch Fluid Plunger | 5/8 Inch Fluid Plunger | 3/4 Inch Fluid Plunger |
| 0 (0, 0) | 15.0 (0.1, 1.0) | 15.0 (0.1, 1.0) | 15.0 (0.1, 1.0) | 15.0 (0.1, 1.0) | 15.0 (0.1, 1.0) |
| 250 (1.7, 17.2) | 15.0 (0.1, 1.0) | 15.0 (0.1, 1.0) | 15.0 (0.1, 1.0) | 15.0 (0.1, 1.0) | 15.0 (0.1, 1.0) |
| 500 (3.4, 34.5) | 15.0 (0.1, 1.0) | 15.0 (0.1, 1.0) | 15.0 (0.1, 1.0) | 15.9 (0.1, 1.1) | 23.0 (0.2, 1.6) |
| 750 (5.2, 51.7) | 15.0 (0.1, 1.0) | 15.0 (0.1, 1.0) | 15.3 (0.1, 1.1) | 23.9 (0.2, 1.6) | 34.4 (0.2, 2.4) |
| 1000 (6.9, 68.9) | 15.0 (0.1, 1.0) | 15.0 (0.1, 1.0) | 20.4 (0.1, 1.4) | 31.9 (0.2, 2.2) | 45.9 (0.3, 3.2) |
| 1250 (8.6, 86.2) | 15.0 (0.1, 1.0) | 15.0 (0.1, 1.0) | 25.5 (0.2, 1.8) | 39.9 (0.3, 2.7) | 57.4 (0.4, 4.0) |
| 1500 (10.3, 103.4) | 15.0 (0.1, 1.0) | 17.2 (0.1, 1.2) | 30.6 (0.2, 2.1) | 47.8 (0.3, 3.3) | 68.9 (0.5, 4.7) |
| 1750 (12.1, 120.7) | 15.0 (0.1, 1.0) | 20.1 (0.1, 1.4) | 35.7 (0.2, 2.5) | 55.8 (0.4, 3.8) | 80.4 (0.6, 5.5) |
| 2180 (15.0, 150.3) | 15.0 (0.1, 1.0) | 25.0 (0.2, 1.7) | 44.5 (0.3, 3.1) | 69.5 (0.5, 4.8) | 100.1 (0.7, 6.9) |
| 2250 (15.5, 155.1) | 15.0 (0.1, 1.0) | 25.8 (0.2, 1.8) | 45.9 (0.3, 3.2) | 71.7 (0.5, 4.9) | |
| 2500 (17.2, 172.4) | 15.0 (0.1, 1.0) | 28.7 (0.2, 2.0) | 51.0 (0.4, 3.5) | 79.7 (0.5, 5.5) | |
| 2750 (19.0, 189.6) | 15.0 (0.1, 1.0) | 31.6 (0.2, 2.2) | 56.1 (0.4, 3.9) | 87.7 (0.6, 6.0) | |
| 3136 (21.6, 216.2) | 16.0 (0.1, 1.1) | 36.0 (0.2, 2.5) | 64.0 (0.4, 4.4) | 100.0 (0.7, 6.9) | |
| 3250 (22.4, 224.1) | 16.6 (0.1, 1.1) | 37.3 (0.3, 2.6) | 66.3 (0.5, 4.6) | | |
| 3500 (24.1, 241.3) | 17.9 (0.1, 1.2) | 40.2 (0.3, 2.8) | 71.4 (0.5, 4.9) | | |
| 3750 (25.9, 258.6) | 19.1 (0.1, 1.3) | 43.0 (0.3, 3.0) | 76.5 (0.5, 5.3) | | |
| 4000 (27.6, 275.8) | 20.4 (0.1, 1.4) | 45.9 (0.3, 3.2) | 81.6 (0.6, 5.6) | | |
| 4250 (29.3, 293.0) | 21.7 (0.1, 1.5) | 48.8 (0.3, 3.4) | 86.7 (0.6, 6.0) | | |
| 4500 (31.0, 310.3) | 23.0 (0.2, 1.6) | 51.7 (0.4, 3.6) | 91.8 (0.6, 6.3) | | |
| 4900 (33.8, 337.8) | 25.0 (0.2, 1.7) | 56.3 (0.4, 3.9) | 100.0 (0.7, 6.9) | | |
| 5000 (34.5, 344.7) | 25.5 (0.2, 1.8) | 57.4 (0.4, 4.0) | | | |
| 5250 (36.2, 362.0) | 26.8 (0.2, 1.8) | 60.3 (0.4, 4.2) | | | |
| 5500 (37.9, 379.2) | 28.1 (0.2, 1.9) | 63.1 (0.4, 4.4) | | | |
| 5750 (39.6, 396.4) | 29.3 (0.2, 2.0) | 66.0 (0.5, 4.6) | | | |
| 6000 (41.4, 413.7) | 30.6 (0.2, 2.1) | 68.9 (0.5, 4.7) | | | |
| 6250 (43.1, 430.9) | 31.9 (0.2, 2.2) | 71.7 (0.5, 4.9) | | | |
| 6500 (44.8, 448.2) | 33.2 (0.2, 2.3) | 74.6 (0.5, 5.1) | | | |
| 6750 (46.5, 465.4) | 34.4 (0.2, 2.4) | 77.5 (0.5, 5.3) | | | |
| 7000 (48.3, 482.6) | 35.7 (0.2, 2.5) | 80.4 (0.6, 5.5) | | | |
| 7250 (50.0, 499.9) | 37.0 (0.3, 2.6) | 83.2 (0.6, 5.7) | | | |
| 7500 (51.7, 517.1) | 38.3 (0.3, 2.6) | 86.1 (0.6, 5.9) | | | |
| 7750 (53.4, 534.3) | 39.5 (0.3, 2.7) | 89.0 (0.6, 6.1) | | | |
| 8000 (55.2, 551.6) | 40.8 (0.3, 2.8) | 91.8 (0.6, 6.3) | | | |
| 8250 (56.9, 568.8) | 42.1 (0.3, 2.9) | 94.7 (0.7, 6.5) | | | |
| 8700 (60.0, 599.8) | 44.4 (0.3, 3.1) | 99.9 (0.7, 6.9) | | | |
| 8750 (60.3, 603.3) | 44.6 (0.3, 3.1) | | | | |
| 9000 (62.1, 620.5) | 45.9 (0.3, 3.2) | | | | |
| 9250 (63.8, 637.8) | 47.2 (0.3, 3.3) | | | | |
| 9500 (65.5, 655.0) | 48.5 (0.3, 3.3) | | | | |
| 9750 (67.2, 672.2) | 49.7 (0.3, 3.4) | | | | |
| 10000 (68.9, 689.5) | 51.0 (0.4, 3.5) | | | | |
| 10250 (70.7, 706.7) | 52.3 (0.4, 3.6) | | | | |
| 10500 (72.4, 723.9) | 53.6 (0.4, 3.7) | | | | |
| 10750 (74.1, 741.2) | 54.8 (0.4, 3.8) | | | | |
| 11000 (75.8, 758.4) | 56.1 (0.4, 3.9) | | | | |
| 11250 (77.6, 775.7) | 57.4 (0.4, 4.0) | | | | |
| 11500 (79.3, 792.9) | 58.7 (0.4, 4.0) | | | | |
| 11750 (81.0, 810.1) | 59.9 (0.4, 4.1) | | | | |
| 12000 (82.7, 827.4) | 61.2 (0.4, 4.2) | | | | |

For applications where the exhaust is ported to a pressurized location, compute the difference between the inlet and outlet pressures to get the pneumatic pressure to be used in the above tables. Minimum pressure differential is 15 psi (0.1 Mpa, 1.0 bar).

NOTE: Regardless of exhaust pressure, maximum inlet pressure is 100 psi (0.7 MPa, 6.9 bar), unless otherwise noted in **Models** on page 3.

| 450 Pneumatic Motor Minimum Gas Pressure psi (MPa, bar) | | | | | |
|----------------------------------------------------------------|-------------------------------|-------------------------------|-------------------------------|-------------------------------|-------------------------------|
| Outlet Pressure psi (MPa, bar) | 1/4 Inch Fluid Plunger | 3/8 Inch Fluid Plunger | 1/2 Inch Fluid Plunger | 5/8 Inch Fluid Plunger | 3/4 Inch Fluid Plunger |
| 0 (0, 0) | 15.0 (0.1, 1.0) | 15.0 (0.1, 1.0) | 15.0 (0.1, 1.0) | 15.0 (0.1, 1.0) | 15.0 (0.1, 1.0) |
| 250 (1.7, 17.2) | 15.0 (0.1, 1.0) | 15.0 (0.1, 1.0) | 15.0 (0.1, 1.0) | 15.0 (0.1, 1.0) | 15.0 (0.1, 1.0) |
| 500 (3.4, 34.5) | 15.0 (0.1, 1.0) | 15.0 (0.1, 1.0) | 15.0 (0.1, 1.0) | 15.0 (0.1, 1.0) | 15.0 (0.1, 1.0) |
| 750 (5.2, 51.7) | 15.0 (0.1, 1.0) | 15.0 (0.1, 1.0) | 15.0 (0.1, 1.0) | 15.0 (0.1, 1.0) | 20.8 (0.1, 1.4) |
| 1000 (6.9, 68.9) | 15.0 (0.1, 1.0) | 15.0 (0.1, 1.0) | 15.0 (0.1, 1.0) | 19.3 (0.1, 1.3) | 27.8 (0.2, 1.9) |
| 1250 (8.6, 86.2) | 15.0 (0.1, 1.0) | 15.0 (0.1, 1.0) | 15.4 (0.1, 1.1) | 24.1 (0.2, 1.7) | 34.7 (0.2, 2.4) |
| 1500 (10.3, 103.4) | 15.0 (0.1, 1.0) | 15.0 (0.1, 1.0) | 18.5 (0.1, 1.3) | 28.9 (0.2, 2.0) | 41.7 (0.3, 2.9) |
| 1750 (12.1, 120.7) | 15.0 (0.1, 1.0) | 15.0 (0.1, 1.0) | 21.6 (0.1, 1.5) | 33.8 (0.2, 2.3) | 48.6 (0.3, 3.4) |
| 2000 (13.8, 137.9) | 15.0 (0.1, 1.0) | 15.0 (0.1, 1.0) | 24.7 (0.2, 1.7) | 38.6 (0.3, 2.7) | 55.6 (0.4, 3.8) |
| 2250 (15.5, 155.1) | 15.0 (0.1, 1.0) | 15.6 (0.1, 1.1) | 27.8 (0.2, 1.9) | 43.4 (0.3, 3.0) | 62.5 (0.4, 4.3) |
| 2500 (17.2, 172.4) | 15.0 (0.1, 1.0) | 17.4 (0.1, 1.2) | 30.9 (0.2, 2.1) | 48.2 (0.3, 3.3) | 69.4 (0.5, 4.8) |
| 2750 (19.0, 189.6) | 15.0 (0.1, 1.0) | 19.1 (0.1, 1.3) | 34.0 (0.2, 2.3) | 53.0 (0.4, 3.7) | 76.4 (0.5, 5.3) |
| 3000 (20.7, 206.8) | 15.0 (0.1, 1.0) | 20.8 (0.1, 1.4) | 37.0 (0.3, 2.6) | 57.9 (0.4, 4.0) | 83.3 (0.6, 5.7) |
| 3250 (22.4, 224.1) | 15.0 (0.1, 1.0) | 22.6 (0.2, 1.6) | 40.1 (0.3, 2.8) | 62.7 (0.4, 4.3) | 90.3 (0.6, 6.2) |
| 3600 (24.8, 248.2) | 15.0 (0.1, 1.0) | 25.0 (0.2, 1.7) | 44.4 (0.3, 3.1) | 69.4 (0.5, 4.8) | 100.0 (0.7, 6.9) |
| 3750 (25.9, 258.6) | 15.0 (0.1, 1.0) | 26.0 (0.2, 1.8) | 46.3 (0.3, 3.2) | 72.3 (0.5, 5.0) | |
| 4000 (27.6, 275.8) | 15.0 (0.1, 1.0) | 27.8 (0.2, 1.9) | 49.4 (0.3, 3.4) | 77.2 (0.5, 5.3) | |
| 4250 (29.3, 293.0) | 15.0 (0.1, 1.0) | 29.5 (0.2, 2.0) | 52.5 (0.4, 3.6) | 82.0 (0.6, 5.7) | |
| 4500 (31.0, 310.3) | 15.0 (0.1, 1.0) | 31.3 (0.2, 2.2) | 55.6 (0.4, 3.8) | 86.8 (0.6, 6.0) | |
| 4750 (32.8, 327.5) | 15.0 (0.1, 1.0) | 33.0 (0.2, 2.3) | 58.6 (0.4, 4.0) | 91.6 (0.6, 6.3) | |
| 5200 (35.9, 358.5) | 16.0 (0.1, 1.1) | 36.1 (0.2, 2.5) | 64.2 (0.4, 4.4) | 100.3 (0.7, 6.9) | |
| 5250 (36.2, 362.0) | 16.2 (0.1, 1.1) | 36.5 (0.3, 2.5) | 64.8 (0.4, 4.5) | | |
| 5500 (37.9, 379.2) | 17.0 (0.1, 1.2) | 38.2 (0.3, 2.6) | 67.9 (0.5, 4.7) | | |
| 5750 (39.6, 396.4) | 17.7 (0.1, 1.2) | 39.9 (0.3, 2.8) | 71.0 (0.5, 4.9) | | |
| 6000 (41.4, 413.7) | 18.5 (0.1, 1.3) | 41.7 (0.3, 2.9) | 74.1 (0.5, 5.1) | | |
| 6250 (43.1, 430.9) | 19.3 (0.1, 1.3) | 43.4 (0.3, 3.0) | 77.2 (0.5, 5.3) | | |
| 6500 (44.8, 448.2) | 20.1 (0.1, 1.4) | 45.1 (0.3, 3.1) | 80.2 (0.6, 5.5) | | |
| 6750 (46.5, 465.4) | 20.8 (0.1, 1.4) | 46.9 (0.3, 3.2) | 83.3 (0.6, 5.7) | | |
| 7000 (48.3, 482.6) | 21.6 (0.1, 1.5) | 48.6 (0.3, 3.4) | 86.4 (0.6, 6.0) | | |
| 7250 (50.0, 499.9) | 22.4 (0.2, 1.5) | 50.3 (0.3, 3.5) | 89.5 (0.6, 6.2) | | |
| 7500 (51.7, 517.1) | 23.1 (0.2, 1.6) | 52.1 (0.4, 3.6) | 92.6 (0.6, 6.4) | | |
| 7950 (54.8, 548.1) | 24.5 (0.2, 1.7) | 55.2 (0.4, 3.8) | 98.1 (0.7, 6.8) | | |
| 8100 (55.8, 558.5) | 25.0 (0.2, 1.7) | 56.3 (0.4, 3.9) | 100.0 (0.7, 6.9) | | |
| 8250 (56.9, 568.8) | 25.5 (0.2, 1.8) | 57.3 (0.4, 4.0) | | | |
| 8500 (58.6, 586.1) | 26.2 (0.2, 1.8) | 59.0 (0.4, 4.1) | | | |
| 8750 (60.3, 603.3) | 27.0 (0.2, 1.9) | 60.8 (0.4, 4.2) | | | |
| 9000 (62.1, 620.5) | 27.8 (0.2, 1.9) | 62.5 (0.4, 4.3) | | | |
| 9250 (63.8, 637.8) | 28.5 (0.2, 2.0) | 64.2 (0.4, 4.4) | | | |
| 9500 (65.5, 655.0) | 29.3 (0.2, 2.0) | 66.0 (0.5, 4.5) | | | |
| 9750 (67.2, 672.2) | 30.1 (0.2, 2.1) | 67.7 (0.5, 4.7) | | | |
| 10000 (68.9, 689.5) | 30.9 (0.2, 2.1) | 69.4 (0.5, 4.8) | | | |
| 10250 (70.7, 706.7) | 31.6 (0.2, 2.2) | | | | |
| 10500 (72.4, 723.9) | 32.4 (0.2, 2.2) | | | | |
| 10750 (74.1, 741.2) | 33.2 (0.2, 2.3) | | | | |
| 11000 (75.8, 758.4) | 34.0 (0.2, 2.3) | | | | |
| 11250 (77.6, 775.7) | 34.7 (0.2, 2.4) | | | | |
| 11500 (79.3, 792.9) | 35.5 (0.2, 2.4) | | | | |
| 11750 (81.0, 810.1) | 36.3 (0.3, 2.5) | | | | |
| 12000 (82.7, 827.4) | 37.0 (0.3, 2.6) | | | | |

For applications where the exhaust is ported to a pressurized location, compute the difference between the inlet and outlet pressures to get the pneumatic pressure to be used in the above tables. Minimum pressure differential is 15 psi (0.1 Mpa, 1.0 bar).

NOTE: Regardless of exhaust pressure, maximum inlet pressure is 100 psi (0.7 MPa, 6.9 bar), unless otherwise noted in **Models** on page 3.

Operation

Pressure Relief Procedure



Follow the Pressure Relief Procedure whenever you see this symbol.



This equipment stays pressurized until pressure is manually relieved. To help prevent serious injury from pressurized fluid, such as skin injection and splashing fluid, follow the **Pressure Relief Procedure** when you stop dispensing and before cleaning, checking, or servicing the equipment.

NOTE: Always discharge fluid into an approved container or location.

1. Shut off all fluid and pneumatic lines (A, K, & P) using shutoff valves (H & B).
2. Use a flathead screwdriver to turn the prime/bleed valve (107) slowly counter-clockwise to relieve pressure. (Use a hex wrench to turn the prime/bleed valve housing (106) on PCI-xxx-xxH pumps. See **Configuration Number Matrix**, page 4.)
3. Slowly disconnect fluid lines (K & P) from check valves (L & M).

Flush the Equipment

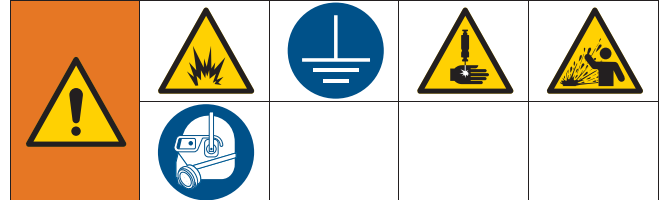

To avoid fire and explosion, always ground equipment and waste container. To avoid static sparking and injury from splashing, always flush at the lowest possible pressure.

- Flush with a fluid that is compatible with the fluid being dispensed and the equipment wetted parts.
1. Follow the **Pressure Relief Procedure**.
 2. Connect inlet to the supply source of the flushing fluid.
 3. Connect outlet to a waste reservoir.
 4. Run the pump until the dispensed fluid is predominately flushing fluid.
 5. Follow the **Pressure Relief Procedure**.

Prime the Pump



1. Verify all connections and fluid lines are tight.
2. In order to prime the pump, turn the prime valve (107) counter-clockwise.

NOTE: The pressure regulator and inlet pneumatic needle valve both effect the pump cycle rate. After inlet pressure is set, the needle valve can serve as a speed control.

3. Adjust pneumatic regulator to desired pressure. See **Minimum Pneumatic Pressures by Fluid Plunger Size and Outlet Pressures** on page 10.
4. Open bleed-type pneumatic valve. Slowly turn pump needle valve counter-clockwise, increasing air/gas flow to the pump.

NOTICE

Pump runaway may occur if the needle valve is opened too far for pressure settings, causing damage to the packing seals (103).

5. Keep the pump cycle rate less than 1 cycle every 3 seconds. The pump is primed when discharge from the prime valve (107) has transitioned from air, to bubbly liquid chemical, to pure liquid chemical.
6. Close the prime valve (107) tightly and verify that fluid has stopped draining from the port.

Calibrate Chemical Dosage



1. Begin the process by setting the pump to an estimated setting of the flow rate. See **Baseline Chemical Dosage Settings**, page 16, for tables of cycles per minute (CPM), and corresponding gallons per day (GPD) and liters per day (LPD).
2. Follow the instructions provided with your calibration gauge in conjunction with the **Baseline Chemical Dosage Settings** on page 16.
3. Adjust the cycle rate with the inlet pneumatic needle valve and/or the pressure regulator.
4. Repeat the test procedure to verify your changes. Repeat as necessary until the desired flow rate is achieved.

Stroke Adjustment

This pump has three defined stroke adjustment positions.

1. Expose the pneumatic motor rod (218) by removing the dust cover (10). See **Disconnect Pump** on page 20.

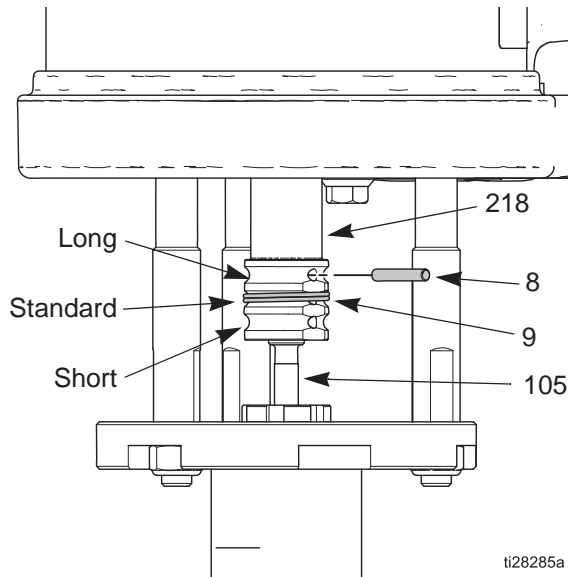

FIG. 2 Retaining spring and connector pin

2. Push the split ring (9) up or down to expose the dowel pin (8).
3. Push out the pin using a screwdriver or punch.
4. Align the desired stroke hole (Long, Standard, or Short) with the hole in the fluid plunger (105). Use a screwdriver to push in the pin (8).
5. Push the split ring (9) into place to cover the pin (8).
6. Replace the dust cover (10).

Baseline Chemical Dosage Settings

See **Stroke Adjustment**, page 15, for stroke adjust settings. See **Performance Charts**, starting on page 43, for maximum flows at any given pressure.

| CPM | 1/8 in. Fluid Plunger Pumps | | | 3/16 in. Fluid Plunger Pumps | | |
|-----|-----------------------------|-----------------|--------------|------------------------------|-----------------|--------------|
| | GPD (LPD) | | | GPD (LPD) | | |
| | Long Stroke | Standard Stroke | Short Stroke | Long Stroke | Standard Stroke | Short Stroke |
| 5 | 0.4 (1.5) | 0.3 (1.1) | 0.2 (0.8) | 1.2 (4.4) | 0.9 (3.3) | 0.6 (2.2) |
| 10 | 0.8 (3.0) | 0.6 (2.3) | 0.4 (1.5) | 2.3 (8.7) | 1.7 (6.5) | 1.2 (4.4) |
| 20 | 1.6 (6.1) | 1.2 (4.5) | 0.8 (3.0) | 4.6 (17.5) | 3.5 (13.1) | 2.3 (8.7) |
| 30 | 2.4 (9.1) | 1.8 (6.8) | 1.2 (4.5) | 6.9 (26.2) | 5.2 (19.6) | 3.5 (13.1) |
| 40 | 3.2 (12.1) | 2.4 (9.1) | 1.6 (6.1) | 9.2 (34.9) | 6.9 (26.2) | 4.6 (17.5) |
| 50 | 4.0 (15.1) | 3.0 (11.4) | 2.0 (7.6) | 11.5 (43.7) | 8.6 (32.7) | 5.8 (21.8) |
| 60 | 4.8 (18.2) | 3.6 (13.6) | 2.4 (9.1) | 13.8 (53.4) | 10.4 (39.3) | 6.9 (26.2) |
| 70 | 5.6 (21.2) | 4.2 (15.9) | 2.8 (10.6) | 16.1 (61.1) | 12.1 (45.8) | 8.1 (30.6) |
| 80 | 6.4 (24.2) | 4.8 (18.2) | 3.2 (12.1) | 18.5 (69.8) | 13.8 (52.4) | 9.2 (34.9) |
| 90 | 7.2 (27.2) | 5.4 (20.4) | 3.6 (13.6) | 20.8 (78.6) | 15.6 (58.9) | 10.4 (39.3) |
| 100 | 8.0 (30.3) | 6.0 (22.7) | 4.0 (15.1) | 23.1 (87.3) | 17.3 (65.5) | 11.5 (43.7) |

| CPM | 1/4 in. Fluid Plunger Pumps | | | 3/8 in. Fluid Plunger Pumps | | |
|-----|-----------------------------|-----------------|--------------|-----------------------------|-----------------|--------------|
| | GPD (LPD) | | | GPD (LPD) | | |
| | Long Stroke | Standard Stroke | Short Stroke | Long Stroke | Standard Stroke | Short Stroke |
| 5 | - | 1.5 (5.6) | 1.0 (3.7) | - | 3.5 (13.1) | 2.3 (8.7) |
| 10 | - | 3.0 (11.2) | 2.0 (7.5) | - | 6.9 (26.2) | 4.6 (17.5) |
| 20 | 7.9 (29.8) | 5.9 (22.4) | 3.9 (14.9) | 18.5 (69.8) | 13.8 (52.4) | 9.2 (34.9) |
| 30 | 11.8 (44.7) | 8.9 (33.5) | 5.9 (22.4) | 27.7 (104.8) | 20.8 (78.6) | 13.8 (52.4) |
| 40 | 15.7 (59.6) | 11.8 (44.7) | 7.9 (29.8) | 36.9 (139.7) | 27.7 (104.8) | 18.5 (69.8) |
| 50 | 19.7 (74.5) | 14.8 (55.9) | 9.8 (37.3) | 46.1 (174.6) | 34.6 (131.0) | 23.1 (87.3) |
| 60 | 23.6 (89.4) | 17.7 (67.1) | 11.8 (44.7) | 55.4 (209.5) | 41.5 (157.2) | 27.7 (104.8) |
| 70 | 27.6 (104.3) | 20.7 (78.2) | 13.8 (52.2) | 64.6 (244.5) | 48.4 (183.3) | 32.3 (122.2) |
| 80 | 31.5 (119.2) | 23.6 (89.4) | 15.7 (59.6) | 73.8 (279.4) | 55.4 (209.5) | 36.9 (139.7) |
| 90 | 35.4 (134.1) | 26.6 (100.6) | 17.7 (67.1) | 83.0 (314.3) | 62.3 (235.7) | 41.5 (157.2) |
| 100 | 39.4 (149.0) | 29.5 (111.8) | 19.7 (74.5) | 92.3 (349.2) | 69.2 (261.9) | 46.1 (174.6) |

| CPM | 1/2 in. Fluid Plunger Pumps | | | 5/8 in. Fluid Plunger Pumps | | |
|-----|-----------------------------|-----------------|--------------|-----------------------------|-----------------|---------------|
| | GPD (LPD) | | | GPD (LPD) | | |
| | Long Stroke | Standard Stroke | Short Stroke | Long Stroke | Standard Stroke | Short Stroke |
| 5 | - | 6.2 (23.3) | 4.1 (15.5) | - | 9.6 (36.4) | 6.4 (24.3) |
| 10 | - | 12.3 (46.6) | 8.2 (31.0) | - | 19.2 (72.8) | 12.8 (48.5) |
| 20 | 32.8 (124.2) | 24.6 (93.1) | 16.4 (62.1) | 51.3 (194.0) | 38.4 (145.5) | 25.6 (97.0) |
| 30 | 49.2 (186.3) | 36.9 (139.7) | 24.6 (93.1) | 76.9 (291.0) | 57.7 (218.3) | 38.4 (145.5) |
| 40 | 65.6 (248.3) | 49.2 (186.3) | 32.8 (124.2) | 102.5 (388.0) | 76.9 (291.0) | 51.3 (194.0) |
| 50 | 82.0 (310.4) | 61.5 (232.8) | 41.0 (155.2) | 128.1 (485.1) | 96.1 (363.8) | 64.1 (242.5) |
| 60 | 98.4 (372.5) | 73.8 (279.4) | 49.2 (186.3) | 153.8 (582.1) | 115.3 (436.5) | 76.9 (291.0) |
| 70 | 114.8 (434.6) | 86.1 (326.0) | 57.4 (217.3) | 179.4 (679.1) | 134.5 (509.3) | 89.7 (339.5) |
| 80 | 131.2 (496.7) | 98.4 (372.5) | 65.6 (248.3) | 205.0 (776.1) | 153.8 (582.1) | 102.5 (388.0) |
| 90 | 147.6 (558.8) | 110.7 (419.1) | 73.8 (279.4) | 230.6 (873.1) | 173.0 (654.8) | 115.3 (436.5) |
| 100 | 164.0 (620.9) | 123.0 (465.6) | 82.0 (310.4) | 256.3 (970.1) | 192.2 (727.6) | 128.1 (485.1) |

| CPM | 3/4 in. Fluid Plunger Pumps | | |
|-----|-----------------------------|-----------------|---------------|
| | GPD (LPD) | | |
| | Long Stroke | Standard Stroke | Short Stroke |
| 5 | - | 13.8 (52.4) | 9.2 (34.9) |
| 10 | - | 27.7 (104.8) | 18.5 (69.8) |
| 20 | 73.8 (279.4) | 55.4 (209.5) | 36.9 (139.7) |
| 30 | 110.7 (419.1) | 83.0 (314.3) | 55.4 (209.5) |
| 40 | 147.6 (558.8) | 110.7 (419.1) | 73.8 (279.4) |
| 50 | 184.5 (698.5) | 138.4 (523.9) | 92.3 (349.2) |
| 60 | 221.4 (838.2) | 166.1 (628.6) | 110.7 (419.1) |
| 70 | 258.3 (977.9) | 193.7 (733.4) | 129.2 (488.9) |
| 80 | 295.2 (1117.6) | 221.4 (838.2) | 147.6 (558.8) |
| 90 | 332.1 (1257.3) | 249.1 (942.9) | 166.1 (628.6) |
| 100 | 369.0 (1396.9) | 276.8 (1047.7) | 184.5 (698.5) |

NOTE: Standard or short strokes are recommended for cycle rates less than 15 CPM.

Maintenance

Preventive Maintenance Schedule

The operating conditions of your particular pump determines how often maintenance is required. Establish a preventive maintenance schedule by recording when and what kind of maintenance is needed, and then determine a regular schedule for checking your pump.

Tighten Threaded Connections

Check that all threaded connections are tight at routine intervals.

Tighten Packings

The packings included in your pump have the ability to be adjusted to stop leaks that develop when the seals are worn. If a leak develops in the pump's fluid section, tighten the packing nut clockwise by 1/16th of a turn, or lower, until the leak is eliminated. The life of the packing can be affected by over-tightening the packings. If the packing nut needs to be tightened repeatedly after short intervals, replace the packing.

Storage

If the pump is going to be stored for long periods, it is recommended that the pump be flushed with a light-weight oil or rust prohibiter to protect pump components. Store the pump with protective fluid inside whenever possible.

Troubleshooting

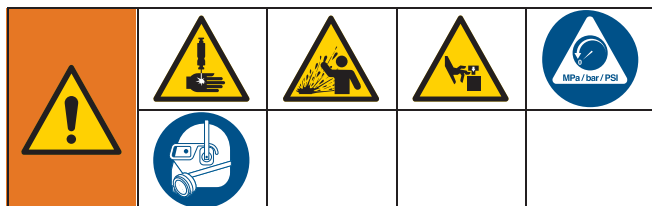

1. Follow **Pressure Relief Procedure**, page 13, before checking or repairing pump.
2. Check all possible problems and causes before disassembling pump.

| Problem | Cause | Solution |
|----------------------------------------------------------------|-------------------------------------------------------------------------|------------------------------------------------------------------------|
| Air bubbles in fluid. | Fluid inlet line is loose. | Tighten. |
| Fluid leaking. | Loose fittings. | Tighten fittings. |
| | Worn seals. | Adjust packing (if leak persists, replace packing). |
| Pump stroking, but no fluid moving. | Air in pump. | Prime pump. |
| | Worn or damaged check valve seals. | Rebuild inlet and outlet check valves. |
| Pneumatic motor will not run. | Damaged pneumatic valve (214). | Replace or service pneumatic valve (214). See page 25. |
| | Damaged pilot valve (213). | Replace pilot valves (213). See page 27. |
| Air continuously exhausting around pneumatic motor piston rod. | Damaged u-cups (207). | Replace piston rod u-cups (207). See page 29. |
| Air continuously exhausting from muffler. | Damaged pneumatic valve plate (305) or cup (312). | Replace or service pneumatic valve (214). See page 25. |
| Pneumatic motor "bounces" at top of stroke. | Damaged bottom pilot valve (213). | Replace bottom pilot valve (213). See page 27. |
| Pneumatic motor "bounces" at bottom of stroke. | Damaged top pilot valve (213). | Replace top pilot valve (213). See page 27. |
| Icing inside motor. | Pneumatic motor operating at high pressure or high cycle rate. | Reduce pressure, cycle rate, or duty cycle of motor. |
| | | Reduce dew point of compressed air in moisture coalescing filter. |
| Pump fails to operate. | Restricted line or inadequate air/gas supply; closed or clogged valves. | Clear line or increase air/gas supply. Check that the valves are open. |
| | Obstructed fluid line; fluid line ID is too small. | Open, clear*; use line with larger ID. |
| Pump operates but does not prime. | Held open or worn check valves or packings. | Clear valve; replace packings. See page 21. |
| Pump operates, but output is low on both strokes. | Restricted line or inadequate air/gas supply; closed or clogged valves. | Clear line or increase air/gas supply. Check that the valves are open. |
| | Obstructed fluid line; fluid line ID is too small. | Open, clear*; use line with larger ID. |
| | Worn packings in pump. | Replace packings. See page 21. |
| Pump operates, but output is low on downstroke. | Held open or worn check valves or packings. | Clear valve; replace packings. See page 21. |
| Erratic or accelerated pump speed. | Exhausted fluid supply. | Refill and prime. |
| | Held open or worn check valves or packings. | Clear valve, replace packings. See page 21. |
| Fluid being pumped is visible on the packing nut. | Worn packings. | Tighten packing nut. |
| | | Replace packings. See page 21. |

Repair



Before servicing or repairing your pump, verify that pressure is relieved according to the **Pressure Relief Procedure**, page 13, and that all fluid and pneumatic lines are properly shut off, or sealed with compatible valves and disconnected.

Pump

Disconnect Pump

1. Follow the **Pressure Relief Procedure**, page 13.
2. Remove the dust cover (10) by loosening the two screws. See FIG. 3.

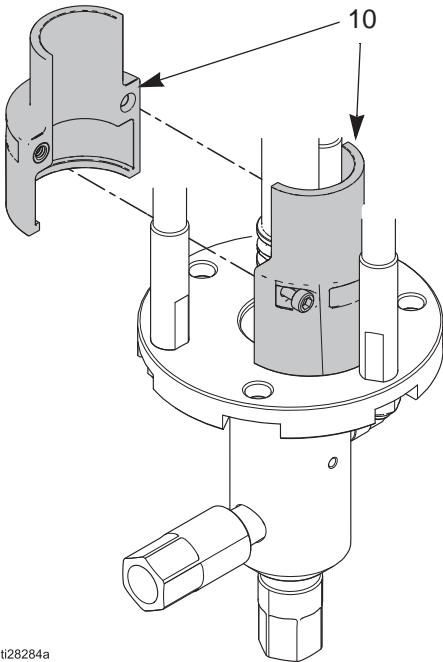

ti28284a

FIG. 3 Remove dust cover

3. Push the retaining spring up and push out the connector pin using a screwdriver or punch. See FIG. 4.

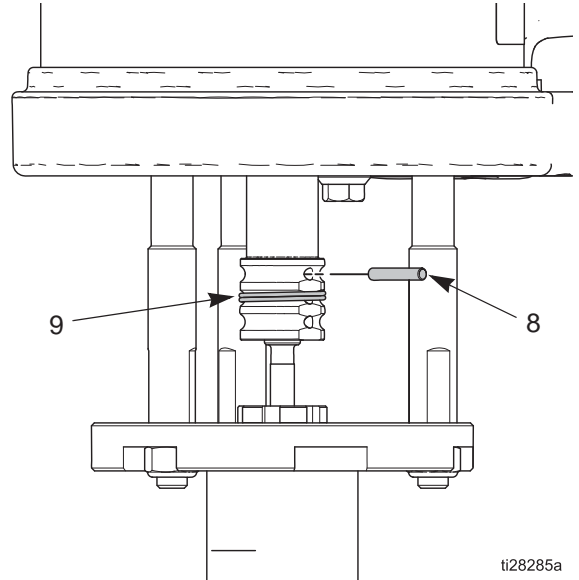

ti28285a

FIG. 4 Retaining spring and connector pin

4. Loosen the fluid cylinder (101) and carefully slide away from the lower pump adapter (5).

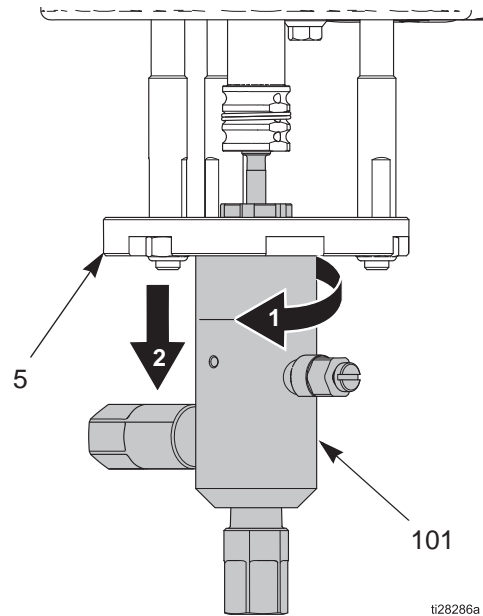

ti28286a

FIG. 5 Remove fluid cylinder

Pump Repair

1. Remove plunger (105) and packing nut (104) from fluid cylinder (101).
2. Carefully remove bearings (102) and packing (103) from the fluid cylinder (101).

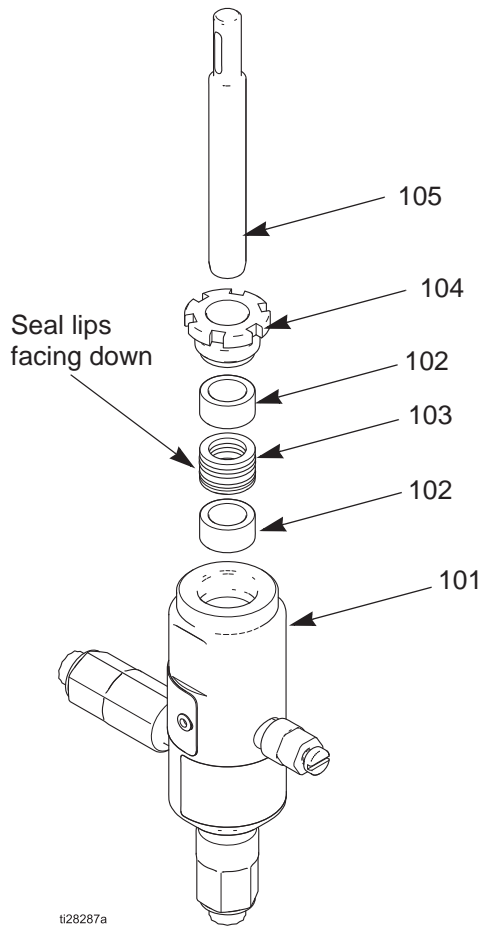

FIG. 6 Remove parts from fluid cylinder

3. Replace packing (103) and bearings (102), if necessary. Lubricate prior to reassembly.

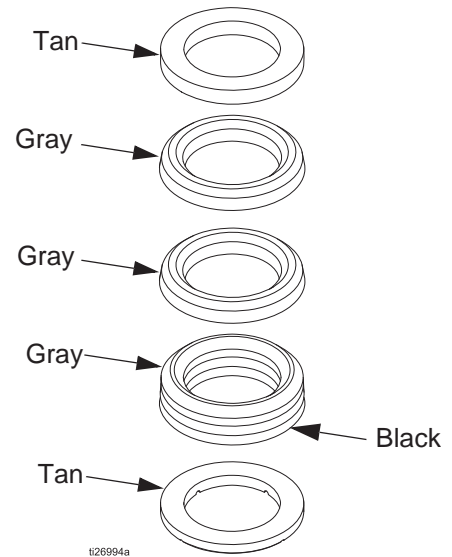

FIG. 7 Packing detailed view

4. Reinsert the first bearing (102), packing (103), second bearing (102), packing nut (104), and plunger (105) into the fluid cylinder (101). Tighten packing nut (104) to distance as shown in FIG. 8.

NOTE: If the packing nut (104) is over-tightened, the pump may not complete a full stroke and seal life will be compromised.

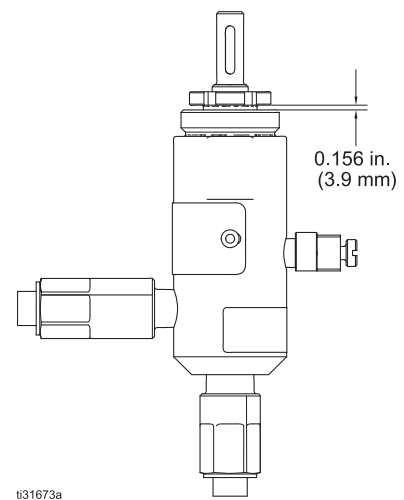

FIG. 8: Tightening the packing nut

Fluid Plunger Repair

1. **Disconnect Pump**, page 20.
2. Remove the fluid plunger (105).
3. Inspect the fluid plunger (105) for wear or damage, and replace if necessary.

NOTE: Lubricate the plunger before replacing it.

Reconnect Pump

NOTICE

The pump can be damaged if the fluid cylinder is not screwed all the way into the adapter plate. Be sure to fully screw the fluid cylinder (101) into the adapter plate (5).

1. Align the hole in the displacement rod with the hole in the pneumatic motor rod. Use a screwdriver to push in the pin (8).

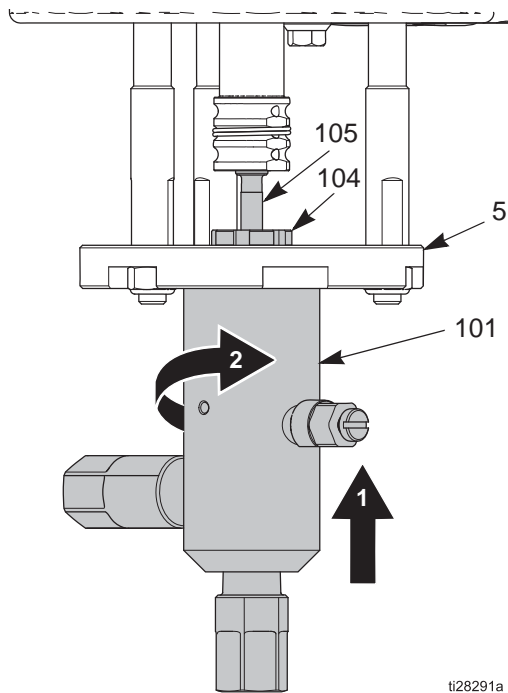

FIG. 9 Reconnect fluid cylinder

2. Screw the fluid cylinder into the adapter plate (nn) until it stops. Tighten fluid cylinder (101) to 30 ft-lbs (40 N•m).

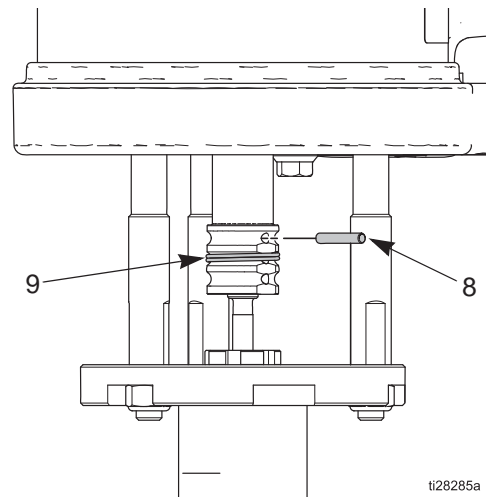

FIG. 10 Retaining spring and connector pin

3. Align the hole in the displacement rod with the hole in the pneumatic motor rod. Use a screwdriver to push in the pin (8).
4. Push the retaining spring (9) into place to cover the pin.
5. Replace the dust cover (10) and secure by tightening the two screws.

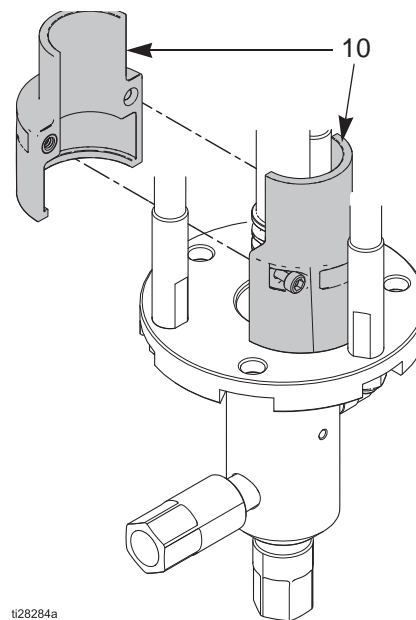

FIG. 11 Replace dust cover

Check Valves



Inlet Check Valve Repair

1. Follow the **Pressure Relief Procedure**, page 13.
2. Remove the inlet check valve assembly (108).

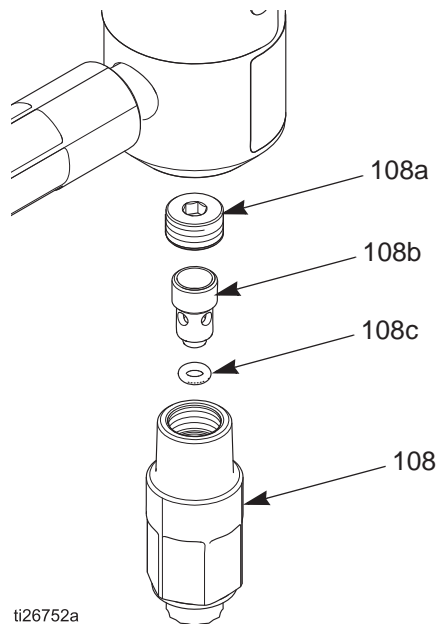

FIG. 12 Inlet check valve assembly

3. Remove the retaining nut (108a) and piston (108b).
4. Remove the piston o-ring (108c).
5. Inspect parts for wear, replace as needed.
6. Install the piston o-ring (108c), piston (108b), and retaining nut (108a).
7. Reconnect the inlet check valve assembly (108).

Inlet Check Valve Repair (models PCI-xxx-xxH only)

1. Follow the **Pressure Relief Procedure**, page 13.
2. Remove the inlet check valve assembly (108).

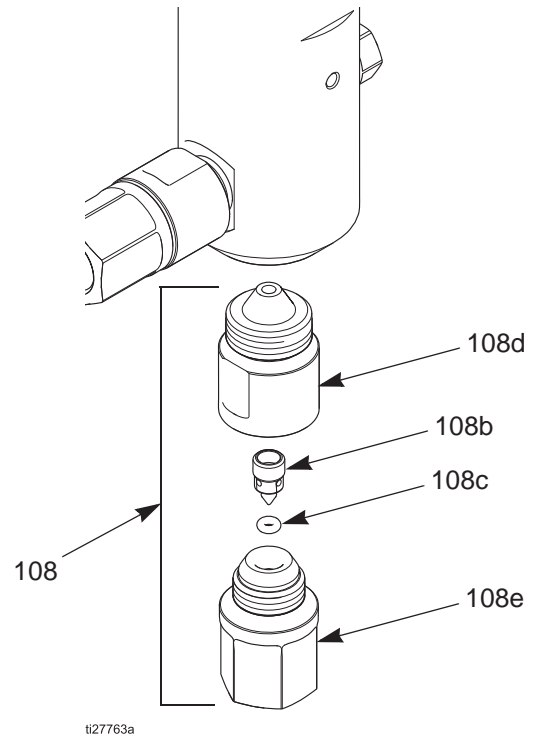

FIG. 13 Inlet check valve assembly

3. Separate the front housing (108d) from the back housing (108e).
4. Remove the piston (108b) and the piston o-ring (108c).
5. Inspect parts for wear, replace as needed.
6. Install the piston o-ring (108c) and piston (108b) in the back housing (108e).
7. Reattach the front housing (108d) to the back housing (108e).
8. Reconnect the inlet check valve assembly (108).

Outlet Check Valve Repair

1. Follow the **Pressure Relief Procedure**, page 13.
2. Remove the outlet check valve assembly (109).

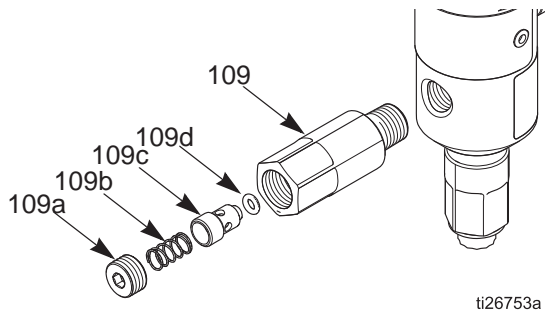

FIG. 14 Outlet check valve assembly

3. Remove the retaining nut (109a), spring (109b), and piston (109c).
4. Remove the piston o-ring (109d).
5. Inspect parts for wear, replace as needed.
6. Install the piston o-ring (109d), piston (109c), spring (109b), and retaining nut (109a).
7. Reconnect the outlet check valve assembly (109).

Outlet Check Valve Repair (models PCI-xxx-xxH only)

1. Follow the **Pressure Relief Procedure**, page 13.
2. Remove the outlet check valve assembly (109).

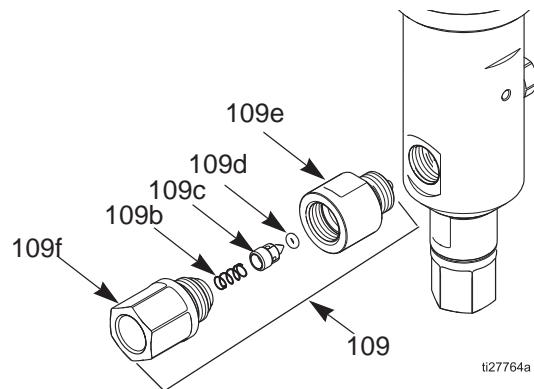

FIG. 15 Outlet check valve assembly

3. Separate the front housing (109e) from the back housing (109f).
4. Remove the spring (109b), piston (109c), and piston o-ring (109d).
5. Inspect parts for wear, replace as needed.
6. Install the piston o-ring (109d), piston (109c), and spring (109b).
7. Reattach the back housing (109f) to the front housing (109e)
8. Reconnect the outlet check valve assembly (109).

Pneumatic Valve



Replace Complete Pneumatic Valve

1. Stop the pump. Follow **Pressure Relief Procedure**, page 13.
2. Disconnect the pneumatic line to the motor.
3. See FIG. 22 on page 30. Remove four screws (211). Remove the pneumatic valve (214) and gasket (209*◆).
4. To repair the pneumatic valve, go to **Disassemble the Pneumatic Valve**, page 25. To install a replacement pneumatic valve, continue with step 5.
5. Align the new pneumatic valve gasket (209*◆) on the manifold, then attach the pneumatic valve (214). Torque screws (211) to 95-105 in-lb (11-12 N•m).
6. Reconnect the pneumatic line to the motor.

Replace Seals or Rebuild Pneumatic Valve

NOTE: Pneumatic Valve Seal Kits are available. See page 39. Parts are marked with an †.

Pneumatic Valve Repair Kits are available. See page 39. Parts are marked with an ◆.

Pneumatic Valve End Cap Kits are available. See page 39. Parts are marked with an ⌘.

Disassemble the Pneumatic Valve

1. Perform steps 1-3 under **Replace Complete Pneumatic Valve**, page 25.
2. See FIG. 16. Use a 2 mm or 5/64 in. hex key to remove two screws (309†◆). Remove the valve plate (305◆), cup (312◆), and spring (311◆).

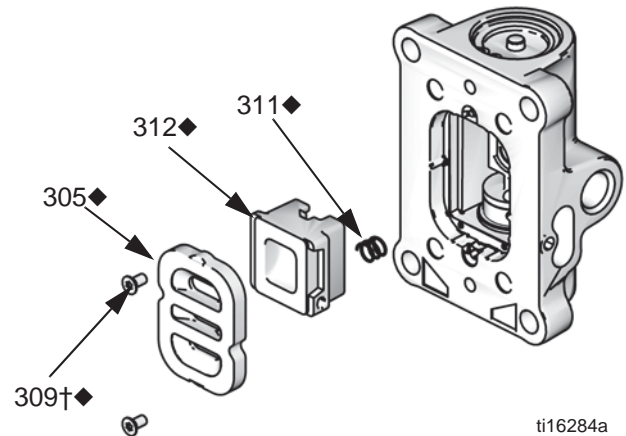
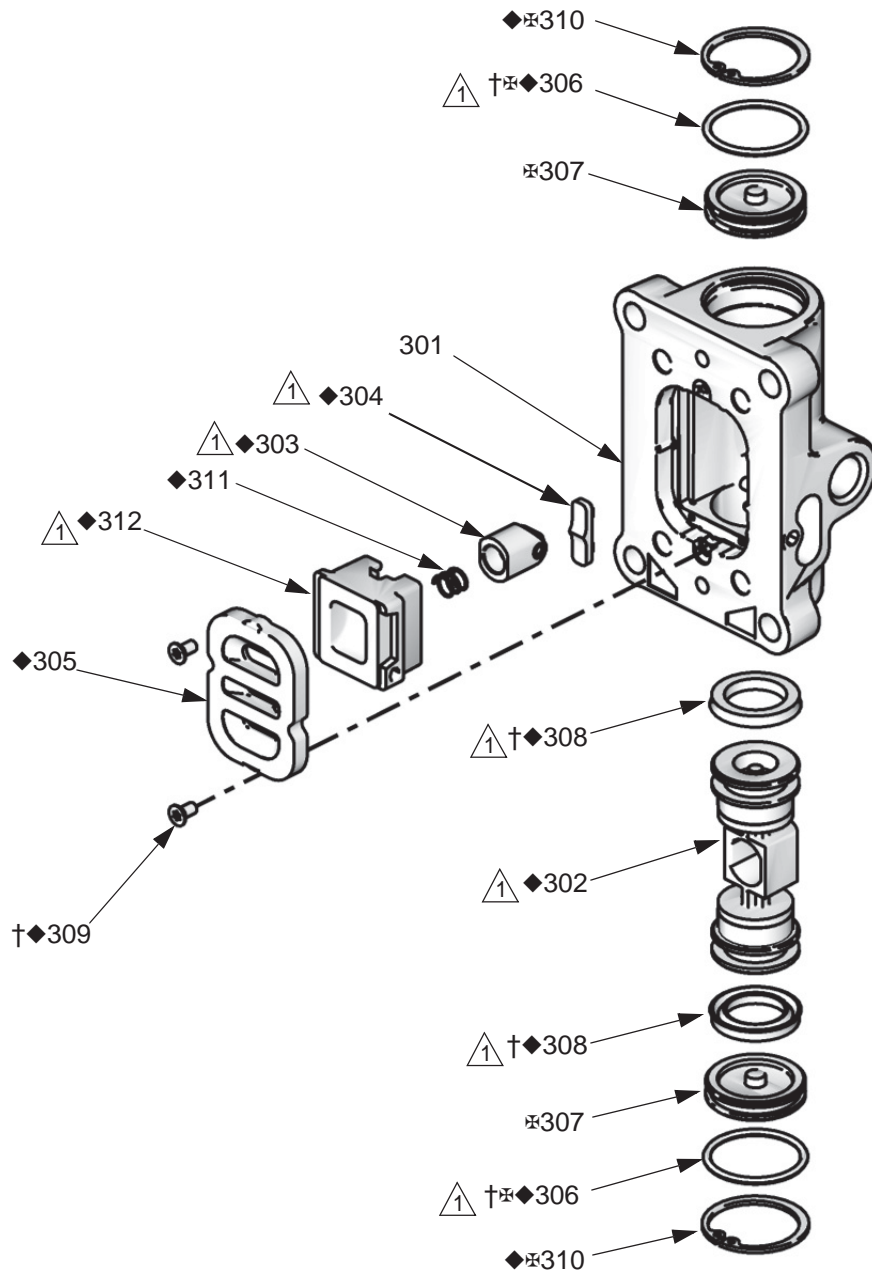

FIG. 16. Pneumatic Plate Removal

3. See FIG. 17. Remove the snap ring (310◆⌘) from each end. Use the piston to push the end caps (307⌘) out of the ends. Remove end cap o-rings (306†⌘◆).
4. Remove the piston (302◆). Remove the u-cup seals (308†◆) from each end, and the detent assembly (303◆) and detent cam (304◆) from the center.



ti16213a

▲ Apply lubricant.

FIG. 17. Pneumatic Valve Assembly

Reassemble the Pneumatic Valve

1. See FIG. 17. Lubricate detent cam (304♦) and install into housing.
2. See FIG. 18. Lubricate the u-cups (308†♦) and install on the piston (302♦) with lips facing toward the center of the piston.

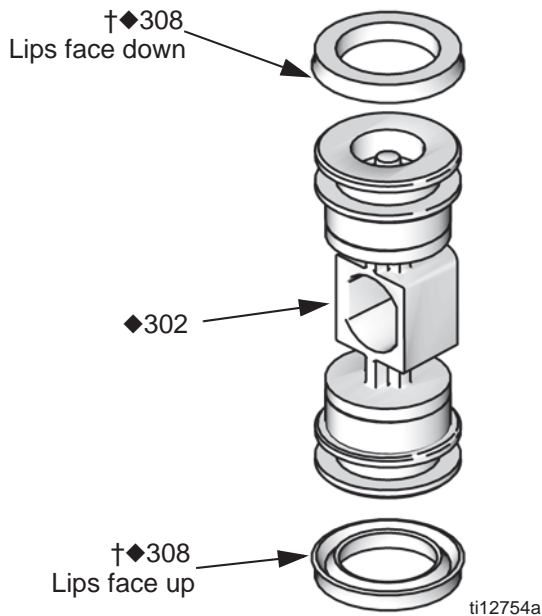

FIG. 18. Pneumatic Valve U-cup Installation

3. See FIG. 17. Lubricate both ends of the piston (302♦) and install it in the housing.
4. Lubricate and install the detent assembly (303♦) into the piston.
5. Lubricate new o-rings (306†*♦) and install on the end caps (307*). Install the end caps into the housing.
6. Install a snap ring (310♦*) on each end to hold end caps in place.

7. Install the spring (311♦). Lubricate and install the pneumatic valve cup (312♦), see FIG. 19. Align the small round magnet with the pneumatic inlet.
8. Install the valve plate (305♦). Tighten the screws (309†♦) to hold it in place.

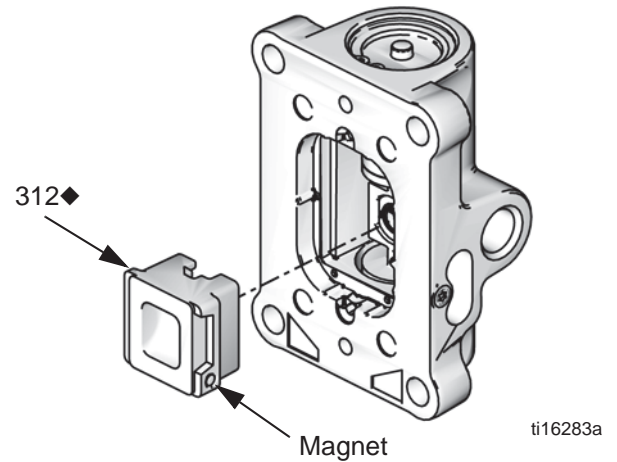

FIG. 19. Pneumatic Valve Cup Installation

Replace Pilot Valves



1. Stop the pump. Follow **Pressure Relief Procedure**, page 13.
2. Disconnect the pneumatic line to the motor.
3. See FIG. 20. Push the safety spring (9) down and hold to access the pilot valve (213) on the bottom cover (201).
4. See FIG. 22 on page 30. Use a 10 mm wrench to remove the old pilot valves (213) from the top and bottom covers.
5. Lubricate and install the new pilot valves (213). Torque to 95-105 in-lb (11-12 N•m).

Disconnect the Pneumatic Motor



1. Stop the pump.
2. Flush the pump, if possible (see page 13). Follow **Pressure Relief Procedure**, page 13.
3. Disconnect the pneumatic line and fluid line and remove the dust guard (10). (See FIG. 3)
4. See FIG. 20. Push the split spring (9) up or down to access the dowel pin (8). Push out the pin, using a screwdriver or punch.
5. Remove the nuts (6) from the bottom of the tie rods (3).
6. Remove the pump lower (7). The adapter plate (5) will remain attached to the pump lower.
7. Remove the split spring (9).
8. Loosen the nuts (4) at the top of the tie rods, then remove the tie rods. The mounting bracket (1) is loosened from the motor as the tie rods are removed.
9. Take the motor to a work bench.
See **Repair Pneumatic Motor** on page 29.

Reconnect the Pneumatic Motor

1. Replace the motor on the mounting bracket (2).
2. Screw the tie rods (3) into the motor, with the top hex nuts (4) attached. Torque the tie rods to 5-10 ft-lb (7-13 N•m).

NOTE: Always tighten the tie rods (3) before tightening the top hex nuts (4).

3. Tighten the top hex nuts (4) to secure the mounting bracket (2).
4. Slide the pump with the adapter plate (5) attached onto the tie rods (3). Ensure that the split spring (9) is in place and the pump outlet is oriented as desired.
5. Install the tie rod nuts (6). Torque to 100 in-lb (11 N•m).
6. Align the hole in the fluid plunger (105) with the hole in the pneumatic motor piston rod (218). Use a screwdriver to push in the dowel pin (8).
7. Push the split spring (9) into place to cover the dowel pin (8).
8. Replace the dust guard (10).

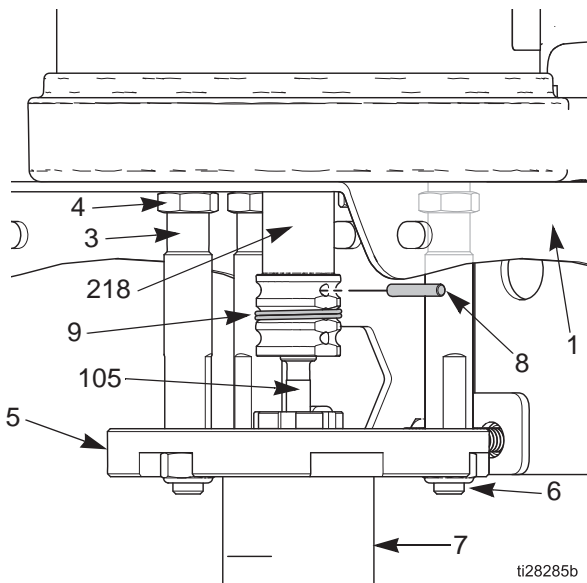

FIG. 20 Retaining spring and connector pin

Repair Pneumatic Motor



NOTE: Complete Pneumatic Motor Replacement Kits are available. Order 24G694 (3.5 in. motor).

NOTE: Pneumatic Motor Seal Kits are available. See page 37 for the correct kit for your motor. Parts included in the kit are marked with an asterisk (*). For best results, use all the parts in the kit.

Disassemble the Pneumatic Motor

1. See FIG. 22. Use a 10 mm socket wrench to remove four screws (211). Remove the pneumatic valve (214) and gasket (209*♦†).
2. Remove four screws (211) and remove the manifold (220) and two gaskets (208*).
3. Use a 10 mm socket wrench to remove the pilot valves (213) from the top and bottom cover.
4. Use a 13 mm socket wrench to remove the tie bolts (212).
5. Remove the top cover (210). Remove the o-ring (202*). *On 3.5 in. motors only*, remove the plug (231) and o-ring (230*).
6. Remove the shield (206) and cylinder (205).
7. Remove the o-ring (204*) from the piston.
8. Secure the piston (219) in a vise with soft jaws. Use a wrench on the flats of the rod (218) to remove the rod and bottom cover assembly (201) from the piston.
9. Remove the rod from the bottom cover assembly.
10. Remove retaining ring (217), u-cup seals (207*), and o-ring (202*) from the bottom cover.

Reassemble the Pneumatic Motor

NOTE: For easier reassembly, start with the top cover (210) turned over on the workbench and assemble the pneumatic motor upside-down.

1. Lubricate and install the o-ring (202*) on the top cover (210).
2. Lubricate the inside of the cylinder (205). Lower the cylinder onto the top cover (210).
3. Install the shield (206) around the cylinder (205) and in the groove on the top cover (210).
4. See FIG. 21. Lubricate and install new u-cup seal (207*) in the bottom of the bearing in the bottom cover (201). The lips must face down. Lubricate and install new u-cup seal (207*) in the top of the bearing. Lips must face up. Install retaining ring (217).

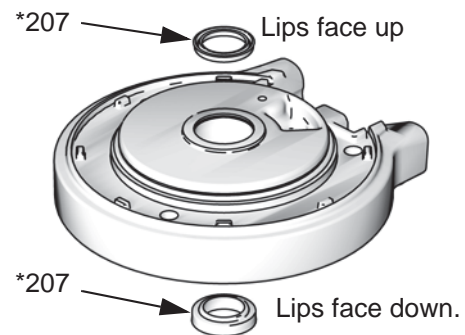

ti16285a

FIG. 21. Pneumatic Motor U-cup Installation

 Apply lubricant.

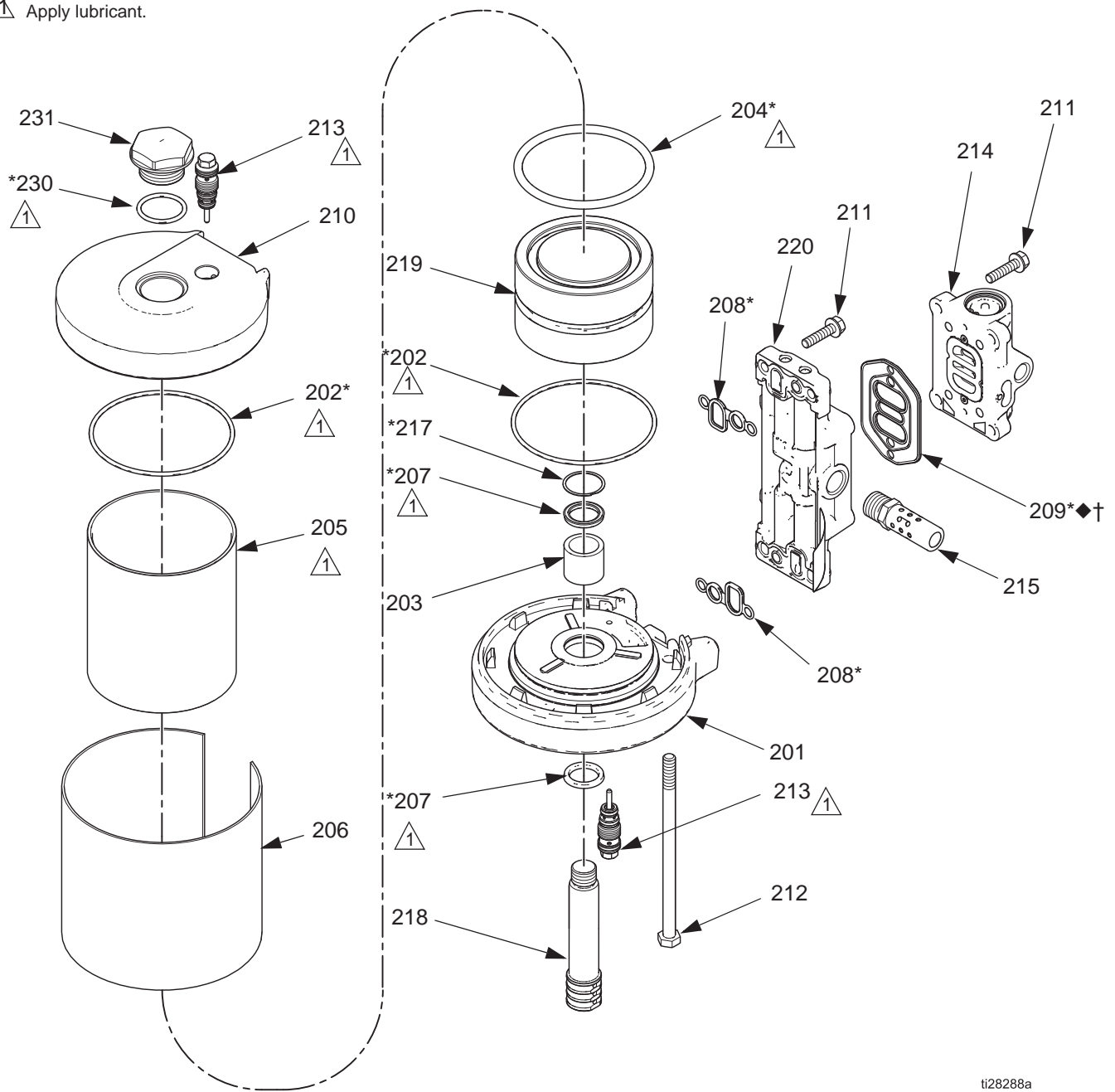

ti28288a

FIG. 22. Pneumatic Motor Assembly

5. Lubricate and install the o-ring (202*) on the bottom cover (201).
 6. Carefully push the threaded end of the rod (218) up through the bottom cover (201).
 7. Apply 16G561 adhesive to the threads of the rod (218). Screw the piston (219) onto the rod. Place the piston in a vise with soft jaws and torque to 35-40 ft-lb (47-54 N•m).
 8. Lubricate and install the o-ring (204*) on the piston (219).
 9. See FIG. 23. Carefully place the bottom cover/piston assembly on the cylinder (205), sliding the piston (219) into the cylinder. The manifold surfaces of the top and bottom covers must align. Be sure the shield (206) is in the groove on both the top and bottom covers.
 10. Install the tie bolts (212) hand tight.
 11. Install two gaskets (208*) on the manifold (220). Install the manifold (220). Torque screws (211) to 95-105 in-lb (10.7-11.9 N•m).
- NOTE:** The manifold is reversible for ease of placement of muffler or remote exhaust.
12. Align the pneumatic valve gasket (209*♦†) on the manifold, then attach the pneumatic valve (214). Torque screws (211) to 95-105 in-lb (11-12 N•m).
 13. Tighten the tie bolts (212) halfway. Work in a criss-cross pattern. Check that the shield (206) remains in the grooves on both covers. Continue tightening the bolts in pattern to 11-13 ft-lb (15-18 N•m).
 14. Lubricate the o-ring (230*). Install it and the plug (231) in the top cover (210).
 15. Lubricate and install pilot valves (213) in top and bottom cover. Torque to 95-105 in-lb (11-12 N•m).
 16. See **Reconnect the Pneumatic Motor** on page 28.

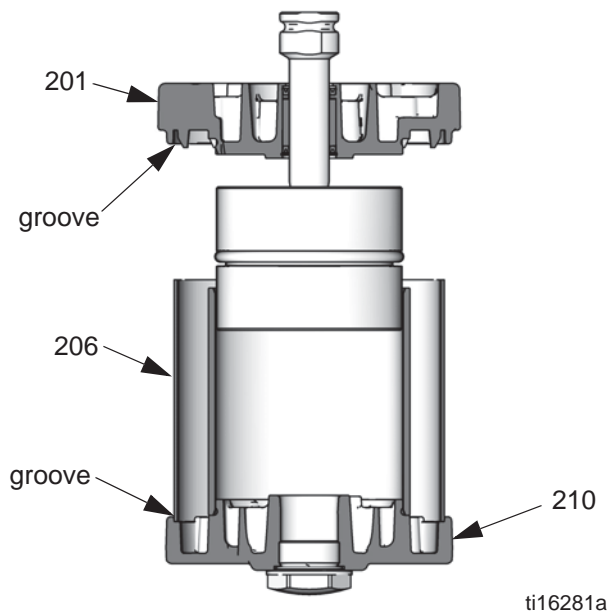
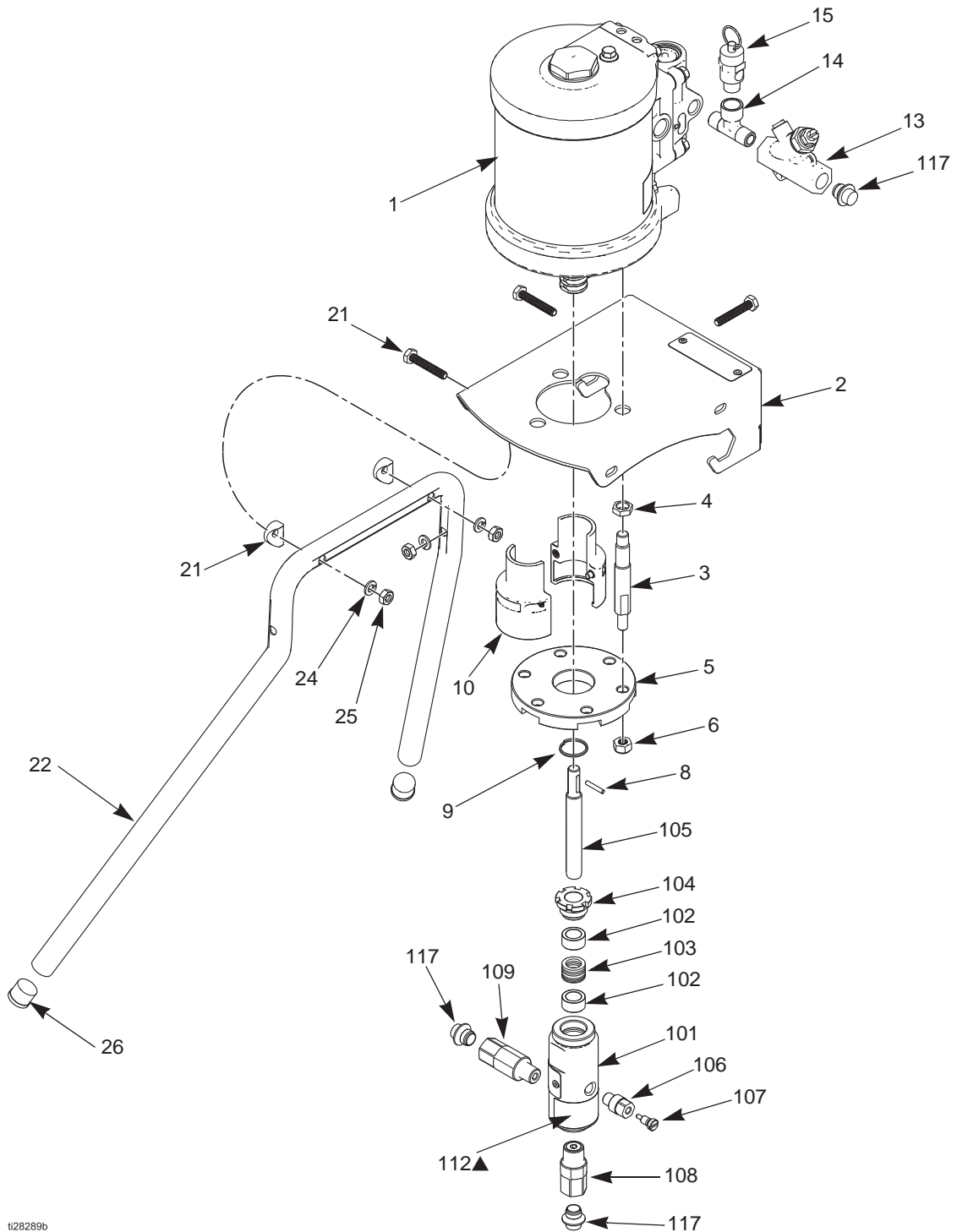

FIG. 23. Align Shield in Grooves on Covers

Parts

Python XL Pneumatic Pump

PCI-350-25H-XA-0 shown



t28289b

Python XL Pump Lower Parts List

| Ref. | Part | Description | Qty. |
|------|--------|---------------------------------------------------------------------------|------|
| 1 | B32982 | Pneumatic motor, 2.5 in. | 1 |
| | B32981 | Pneumatic motor, 3.5 in. | 1 |
| | B32980 | Pneumatic motor, 4.5 in. | 1 |
| 2 | B32272 | Wall bracket, 2.5 in., 3.5 in. | 1 |
| | B32278 | Wall Bracket, 4.5 in. | |
| 3 | B32273 | Motor tie rod | 3 |
| 4 | -- | Jam hex nut | 3 |
| 5 | B32269 | Lower adapter (1/8 in., 3/16 in., 1/4 in., 3/8 in., and 1/2 in. plungers) | 1 |
| | B32270 | Lower adapter (5/8 in. and 3/4 in. plungers) | 1 |
| 6 | -- | Nyloc nut, stainless steel | 3 |
| 7 | -- | Pump lower (includes ref. 101-117) | 1 |
| 8† | B32268 | Dowel pin, stainless steel | 1 |
| 9† | B32268 | Split ring, stainless steel | 1 |
| 10 | B32767 | Dust/hand guard, 2.5 in. | 1 |
| | B32271 | Dust/hand guard, 3.5 in. | 1 |
| | B32277 | Dust/hand guard, 4.5 in. | 1 |
| 11 | -- | ES screw | 2 |
| 12 | -- | Nipple fitting, hex | 1 |
| 13 | B32818 | Needle valve, Viton, stainless steel, NPT, 40 PSI | 1 |
| | B32819 | Needle valve, Viton, stainless steel, NPT, 50 PSI | 1 |
| | B32252 | Needle valve, Viton, stainless steel, NPT, 70 PSI | 1 |
| | B32820 | Needle valve, Viton, stainless steel, NPT, 75 PSI | 1 |
| | B32821 | Needle valve, Viton, stainless steel, NPT, 80 PSI | 1 |
| | B32253 | Needle valve, Viton, stainless steel, NPT, 100 PSI | 1 |
| 14 | -- | Tee, 1/4m x 1/4m x 1/4f | 1 |
| 15 | B32822 | Safety valve, 40 PSI | 1 |
| | B32823 | Safety valve, 50 PSI | 1 |
| | 127731 | Safety valve, 70 PSI | 1 |
| | B32824 | Safety valve, 75 PSI | 1 |
| | B32825 | Safety valve, 80 PSI | 1 |
| | 113498 | Safety valve, 100 PSI | 1 |
| 21 | B32274 | Coved spacer | 4 |
| 22 | B32274 | Stand leg | 2 |
| 23 | B32274 | Hex head bolt, stainless steel | 4 |

| Ref. | Part | Description | Qty. |
|-------|--------------------|--------------------------------------------------------------------------------------------------|------|
| 24 | B32274 | Spring lock washer | 4 |
| 25 | B32274 | Hex nut | 4 |
| 26 | B32274 | Stand leg plug | 4 |
| 101 | See Table 3, pg 34 | Fluid cylinder | 1 |
| 102† | See Table 4, pg 34 | Plunger bearings, included with packing (ref. 103) | 2 |
| 103† | See Table 4, pg 34 | Packing | 1 |
| 104† | See Table 5, pg 34 | Packing nut | 1 |
| 105† | See Table 2, pg 34 | Fluid Plunger | 1 |
| 106† | B32191 | Priming bleed valve housing, standard pressure (3/8 in., 1/2 in., 5/8 in., and 3/4 in. plungers) | 1 |
| | B32250 | Priming bleed valve housing, high pressure (1/8 in., 3/16 in., 1/4 in. plungers) | 1 |
| 107*† | B32192 | Priming bleed valve; included with priming bleed valve housing (ref. 106) | 1 |
| 108† | See Table 6, pg 35 | Inlet valve check | 1 |
| 109† | See Table 7, pg 35 | Outlet valve check | 1 |
| 112▲ | 17G320 | Warning label, adhesive | 1 |
| 117† | -- | Cap plug | 2 |

▲ Replacement Danger and Warning labels, tags, and cards are available at no cost.

* Not included with PCI-xxx-xxH configurations.

† Included with Lower Kit. See **Lower Configuration** on page 4.

Table 2: Fluid Plungers (ref. 105)

| Ref | Part Numbers by Fluid Plunger Size Diameter | | | | | | | Qty. |
|-------------------------------|---------------------------------------------|----------|---------|---------|---------|---------|---------|------|
| | 1/8 in. | 3/16 in. | 1/4 in. | 3/8 in. | 1/2 in. | 5/8 in. | 3/4 in. | |
| Chromex-Coated Fluid Plungers | | | | | | | | |
| 105 | B32826 | B32827 | B32254 | B32255 | B32256 | B32257 | B32258 | 1 |
| Ceramic-Coated Fluid Plungers | | | | | | | | |
| 105 | B32828 | B32829 | B32259 | B32260 | B32261 | B32262 | B32263 | 1 |

Table 3: Fluid Cylinders (ref. 101)

| Ref | Part Numbers by Fluid Plunger Size Diameter | | | | | | | Qty. |
|-----|---------------------------------------------|----------|---------|---------|---------|---------|---------|------|
| | 1/8 in. | 3/16 in. | 1/4 in. | 3/8 in. | 1/2 in. | 5/8 in. | 3/4 in. | |
| 101 | B32180 | B32181 | B32275 | B32183 | B32184 | B32185 | B32180 | 1 |

Table 4: Packing Stacks (ref. 103), including Plunger Bearings (ref. 102)

| Ref | Part Numbers by Fluid Plunger Size Diameter | | | | | | | Qty. |
|--------|---------------------------------------------|----------|---------|---------|---------|---------|---------|------|
| | 1/8 in. | 3/16 in. | 1/4 in. | 3/8 in. | 1/2 in. | 5/8 in. | 3/4 in. | |
| FKM | | | | | | | | |
| 103 | B32115 | B32119 | B32094 | B32098 | B32102 | B32123 | B32127 | 1 |
| FKMETP | | | | | | | | |
| 103 | B32116 | B32120 | B32095 | B32099 | B32103 | B32124 | B32128 | 1 |
| HNBR | | | | | | | | |
| 103 | B32117 | B32121 | B32096 | B32100 | B32104 | B32125 | B32129 | 1 |
| FFKM | | | | | | | | |
| 103 | B32118 | B32122 | B32097 | B32101 | B32105 | B32126 | B32130 | 1 |
| TFE/P | | | | | | | | |
| 103 | B32033 | B32041 | B32042 | B32043 | B32044 | B32085 | B32086 | 1 |

Table 5: Packing Nuts (ref. 104)

| Ref | Part Numbers by Fluid Plunger Size Diameter | | | | | | | Qty. |
|-----|---------------------------------------------|----------|---------|---------|---------|---------|---------|------|
| | 1/8 in. | 3/16 in. | 1/4 in. | 3/8 in. | 1/2 in. | 5/8 in. | 3/4 in. | |
| 104 | B32187 | B32187 | B32264 | B32265 | B32266 | B32267 | B32267 | 1 |

Table 6: Inlet Valve Check (ref. 108)

| Ref | Part Numbers by Fluid Plunger Size Diameter | | | | | | | Qty. |
|--------|---------------------------------------------|----------|---------|---------|---------|---------|---------|------|
| | 1/8 in. | 3/16 in. | 1/4 in. | 3/8 in. | 1/2 in. | 5/8 in. | 3/4 in. | |
| FKM | | | | | | | | |
| 108 | B32226 | B32226 | B32226 | B32024 | B32024 | B32024 | B32024 | 1 |
| FKMETP | | | | | | | | |
| 108 | B32228 | B32228 | B32228 | B32026 | B32026 | B32026 | B32026 | 1 |
| HNBR | | | | | | | | |
| 108 | B32230 | B32230 | B32230 | B32113 | B32113 | B32113 | B32113 | 1 |
| FFKM | | | | | | | | |
| 108 | B32232 | B32232 | B32232 | B32028 | B32028 | B32028 | B32028 | 1 |
| TFE/P | | | | | | | | |
| 109 | B32806 | B32806 | B32806 | B32610 | B32610 | B32610 | B32610 | 1 |

Table 7: Outlet Valve Check (ref. 109)

| Ref | Part Numbers by Fluid Plunger Size Diameter | | | | | | | Qty. |
|--------|---------------------------------------------|----------|---------|---------|---------|---------|---------|------|
| | 1/8 in. | 3/16 in. | 1/4 in. | 3/8 in. | 1/2 in. | 5/8 in. | 3/4 in. | |
| FKM | | | | | | | | |
| 109 | B32227 | B32227 | B32227 | B32025 | B32025 | B32025 | B32025 | 1 |
| FKMETP | | | | | | | | |
| 109 | B32229 | B32229 | B32229 | B32027 | B32027 | B32027 | B32027 | 1 |
| HNBR | | | | | | | | |
| 109 | B32231 | B32231 | B32231 | B32114 | B32114 | B32114 | B32114 | 1 |
| FFKM | | | | | | | | |
| 109 | B32233 | B32233 | B32233 | B32029 | B32029 | B32029 | B32029 | 1 |
| TFE/P | | | | | | | | |
| 109 | B32807 | B32807 | B32807 | B32608 | B32608 | B32608 | B32608 | 1 |

Pneumatic Motor Parts

Part No. B32770, 2.5 in. (63.5 mm); B32251, 3.5 in. (88.9 mm), shown

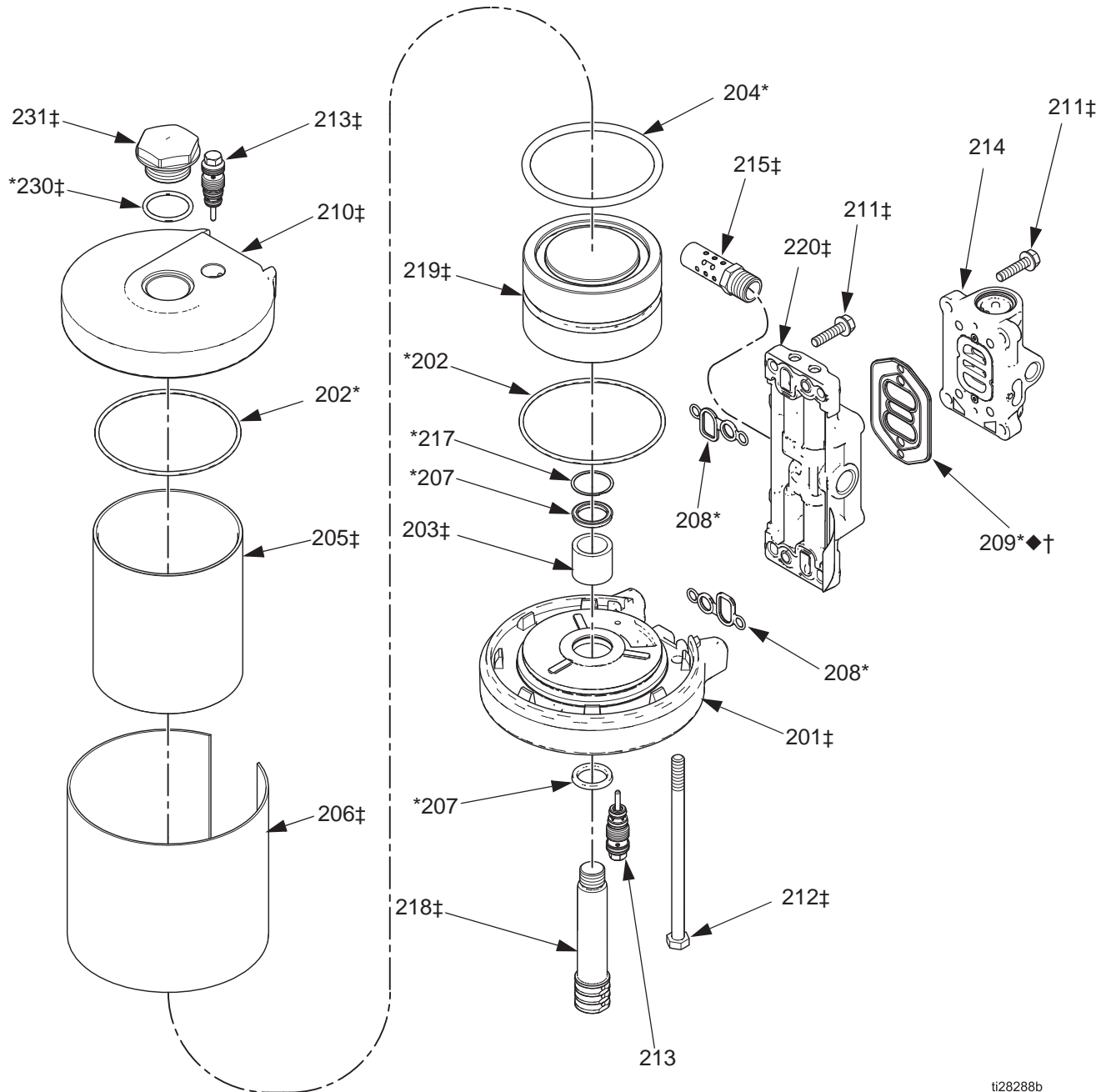

ti28288b

‡ These items are only available in Air Motor Kits B32251 and B32770

Pneumatic Motor Parts

Part number shown:

B32770: 2.5 in. (63.5 mm)

B32251: 3.5 in. (88.9 mm)

B32276: 4.5 in. (114.3 mm)

| Ref. | Part | Description | Qty |
|--------|---------|----------------------------------------------------------------|------|
| 201 | -- | Cover, bottom | 1 |
| 202* | -- | O-Ring, cover | 2 |
| 203 | -- | Bearing | 1 |
| 204* | -- | O-Ring, piston | 1 |
| 205 | -- | Cylinder, motor | 1 |
| 206▲ | B32830 | 2.5 in. cover, cylinder (includes English warning label) | 1 |
| | B32831 | 3.5 in. cover, cylinder (includes English warning label) | 1 |
| | B32832 | 4.5 in. cover, cylinder (includes English warning label) | 1 |
| 229▲ | 15W719 | Label, warning (French and Spanish) (not shown) | 1 |
| 207* | -- | Seal, u-cup | 2 |
| 208* | -- | Gasket, manifold | 2 |
| 209*♦† | -- | Gasket, pneumatic valve | 1 |
| 210 | -- | Cover, top | 1 |
| 211 | -- | Screw, M6 x 25 | 8 |
| 212 | -- | Bolt, tie, hex head | 2, 3 |
| 213 | 24A366 | Valve, pilot (pack of 2) | 1 |
| 214 | 24A351 | Valve, pneumatic; includes items 209 and 211 (qty 4) | 1 |
| 215 | -- | Muffler | 1 |
| 217* | -- | Ring, retaining | 1 |
| 218 | -- | Rod, pneumatic motor | 1 |
| 219 | -- | Kit, piston, motor; includes 204 and 218, and 16G561 adhesive. | 1 |
| 220 | -- | Manifold, assembly, includes 208, 209, and 211 (qty. 4) | 1 |
| 230* | -- | O-Ring, top plug | 1 |
| 231 | -- | Plug, top cover (ref. 210) | 1 |
| | 24A539* | 2.5 in. Motor Seal Kit | 1 |
| | 24G700* | 3.5 in. Motor Seal Kit | 1 |
| | 24E986 | 4.5 in. Motor Seal Kit | 1 |

▲ Replacement Danger and Warning labels, tags, and cards are available at no cost.

† Included in Pneumatic Valve Seal Kit 24A535. See page 39.

♦ Included in Pneumatic Valve Repair Kit 24A537. See page 39.

* Included in Pneumatic Motor Seal Kit 24A539 (2.5 in.), 24G700 (3.5 in.).

Pneumatic Valve Parts

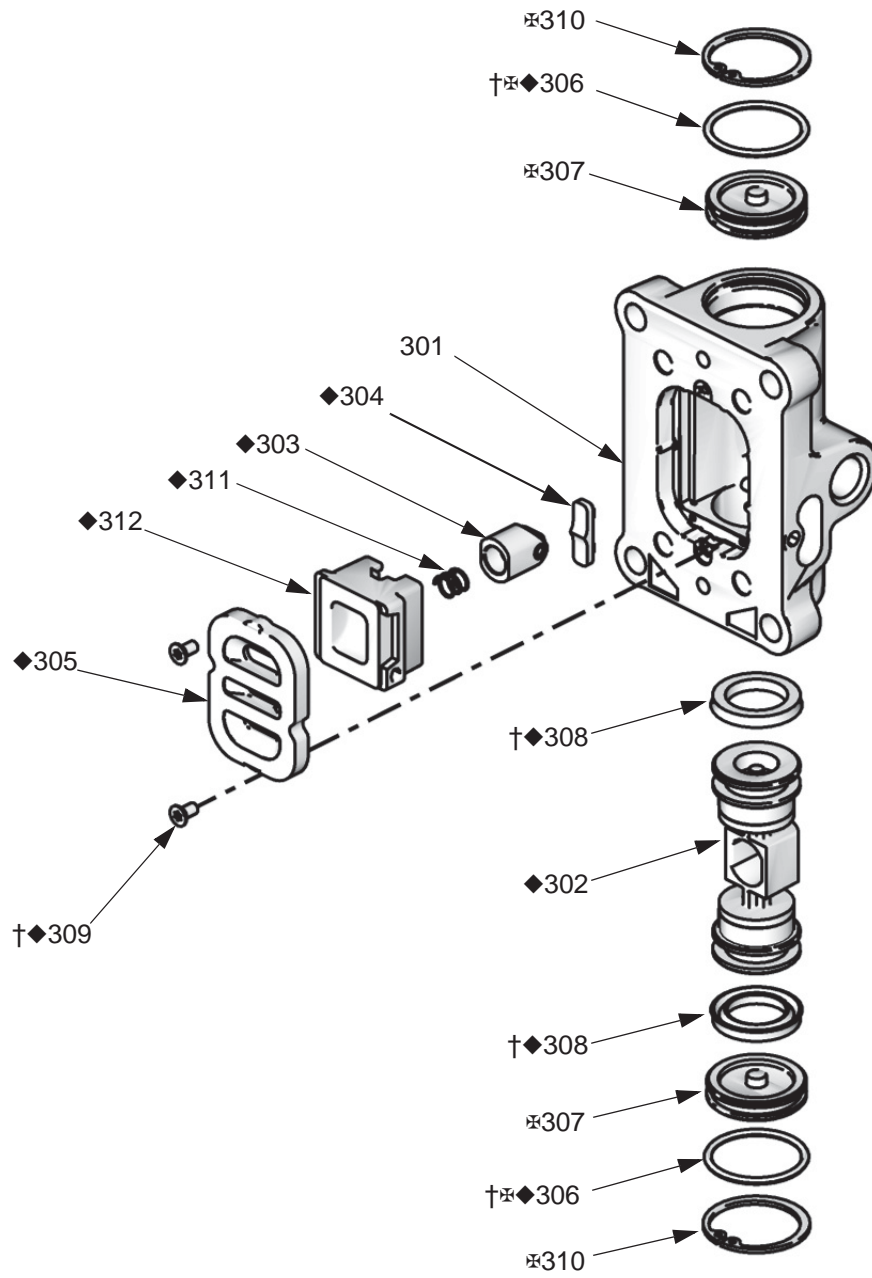

ti16213a

Pneumatic Valve Parts

Complete Pneumatic Valve Replacement Kit 24A351

To replace the complete pneumatic valve, order Pneumatic Valve Replacement Kit 24A351 (2.5 in., 3.5 in.) or Kit 24A352 (4.5 in.). The kit includes items 301-312 below, and items 209 and 211 on page 37.

Pneumatic Valve Repair Kits

Pneumatic valve parts are not sold individually. The table below shows possible kit options for each part.

| Ref. | Description | Qty. | Pneumatic Valve Repair Kit 24A537 (2.5 in., 3.5 in.) 24A538 (4.5 in.) | Pneumatic Valve Seal Kit 24A535 (2.5 in., 3.5 in.) 24A536 (4.5in.) | Pneumatic Valve End Cap Kit 24A360 (2.5 in., 3.5 in.) 24A361 (4.5 in.) |
|--------|------------------------|------|-----------------------------------------------------------------------------|--------------------------------------------------------------------------|------------------------------------------------------------------------------|
| 301 | HOUSING | 1 | | | |
| 302◆ | PNEUMATIC VALVE PISTON | 1 | ✓ | | |
| 303◆ | DETENT PISTON ASSEMBLY | 1 | ✓ | | |
| 304◆ | DETENT CAM | 1 | ✓ | | |
| 305◆ | PLATE, pneumatic valve | 1 | ✓ | | |
| 306†⊕◆ | O-RING | 2 | ✓ | ✓ | ✓ |
| 307⊕ | CAP | 2 | | | ✓ |
| 308†◆ | U-CUP | 2 | ✓ | ✓ | |
| 309†◆ | SCREW | 2 | ✓ | ✓ | |
| 310⊕ | SNAP RING | 2 | ✓ | | ✓ |
| 311◆ | DETENT SPRING | 1 | ✓ | | |
| 312◆ | CUP | 1 | ✓ | | |

† Included in Pneumatic Valve Seal Kit 24A535.

◆ Included in Pneumatic Valve Repair Kit 24A537.

⊕ Included in Pneumatic Valve End Cap Kit 24A360.

Replacement screws (309) are available in a pack of 10. Order Kit 24A359.

Kits and Accessories

Additional Kits & Accessories

| Part No. | Description |
|---------------|------------------------------------------------------------------------------------------------------------------|
| B32045 | 225-750 PSI Pressure Relief Valve Kit (Adjustable) |
| B32046 | 750-1500 PSI Pressure Relief Valve Kit (Adjustable) |
| B32047 | 1500-2250 PSI Pressure Relief Valve Kit (Adjustable) |
| B32048 | 2250-3000 PSI Pressure Relief Valve Kit (Adjustable) |
| B32049 | 3000-4000 PSI Pressure Relief Valve Kit (Adjustable) |
| B32050 | 4000-5000 PSI Pressure Relief Valve Kit (Adjustable) |
| B32051 | 5000-6000 PSI Pressure Relief Valve Kit (Adjustable) |
| B32088 | SST Calibration Column Kit |
| B32089 | SST Manifold Assembly Kit |
| B32157 | 316 SST Ball Valve Kit, 3/4 in. NPT(F) |
| B32158 | Fluid Filter 6000 PSI |
| B32159 | Fluid Filter 10000 PSI |
| B32160 | Float Switch |
| B32162 | 1/4 in. NPT(F) X 1/4 in. NPT(F) Check Kit |
| B32038 | FKM Large (3/8 in. - 3/4 in.) Inlet and Outlet Check Valve Repair Kit (includes a spring and piston o-rings) |
| B32039 | FKM ETP Large (3/8 in. - 3/4 in.) Inlet and Outlet Check Valve Repair Kit (includes a spring and piston o-rings) |
| B32040 | FFKM Large (3/8 in. - 3/4 in.) Inlet and Outlet Check Valve Repair Kit (includes a spring and piston o-rings) |
| B32111 | HNBR Large (3/8 in. - 3/4 in.) Inlet and Outlet Check Valve Repair Kit (includes a spring and piston o-rings) |
| B32870 | TFE/P Large (3/8 in. - 3/4 in.) Inlet and Outlet Check Valve Repair Kit (includes a spring and piston o-rings) |
| B32224 | FKM Small (1/4 in.) Inlet and Outlet Check Valve Repair Kit (includes a spring and piston o-rings) |

| | |
|---------------|--------------------------------------------------------------------------------------------------------|
| B32225 | FKM ETP Small (1/4 in.) Inlet and Outlet Check Valve Repair Kit (includes a spring and piston o-rings) |
| B32235 | FFKM Small (1/4 in.) Inlet and Outlet Check Valve Repair Kit (includes a spring and piston o-rings) |
| B32234 | HNBR Small (1/4 in.) Inlet and Outlet Check Valve Repair Kit (includes a spring and piston o-rings) |
| B32871 | TFE/P Small (1/4 in.) Inlet and Outlet Check Valve Repair Kit (includes a spring and piston o-rings) |
| B32240 | HF4 to 1/4 in. Adapter; 10,000 PSI (1/8 in.-3/16 in. plungers) |

Dimensions

Python XL Pump Dimensions

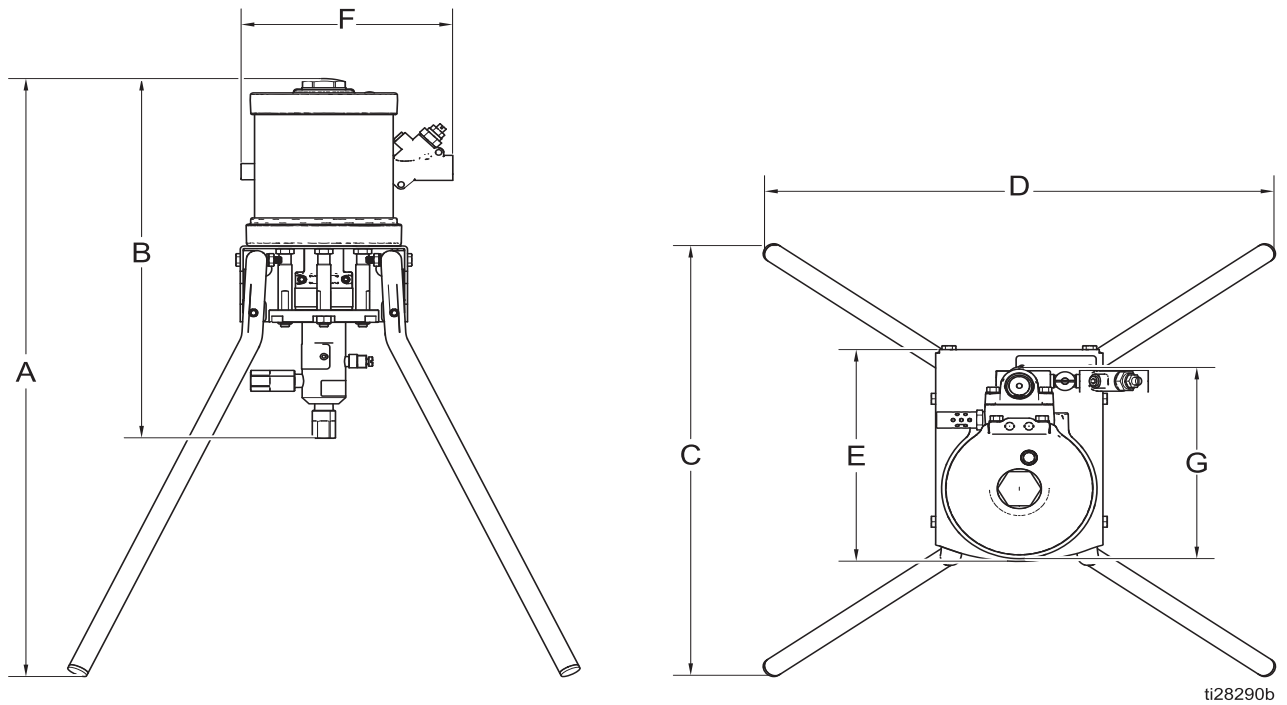

ti28290b

FIG. 24 Python Pump Dimensions

| Size | A | B | C | D | E | F | G |
|------|-----------------------|-----------------------|------------------------|------------------------|-----------------------|------------------------|-----------------------|
| 250 | 24.0 in. (61.0 cm) | 14.5 in. (36.8 cm) | 16.75 in. (42.5 cm) | 17.75 in. (45.1 cm) | 8.0 in. (20.3 cm) | 7.62 in. (19.4 cm) | 6.0 in. (15.2 cm) |
| 350 | 24.0 in. (61.0 cm) | 14.5 in. (36.8 cm) | 16.75 in. (42.5 cm) | 17.75 in. (45.1 cm) | 8.0 in. (20.3 cm) | 3.62 in. (9.2 cm) | 7.70 in. (19.6 cm) |
| 450 | 24.0 in. (61.0 cm) | 14.5 in. (36.8 cm) | 16.75 in. (42.5 cm) | 19.25 in. (48.9 cm) | 9.94 in. (25.5 cm) | 13.16 in. (33.4 cm) | 9.19 in. (23.3 cm) |

Wall Bracket Mounting Hole Diagram, 2.5 in. & 3.5 in.

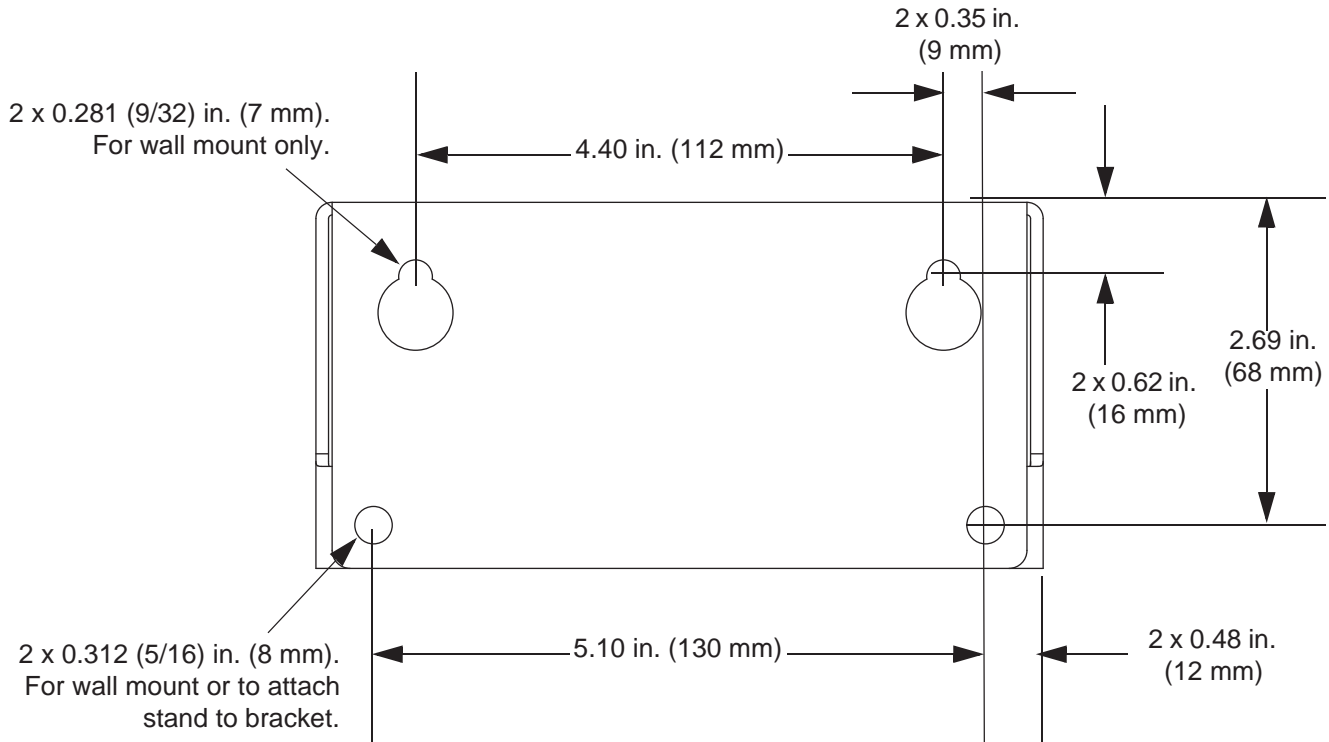

TI16289a

Wall Bracket Mounting Hole Diagram, 4.5 in.

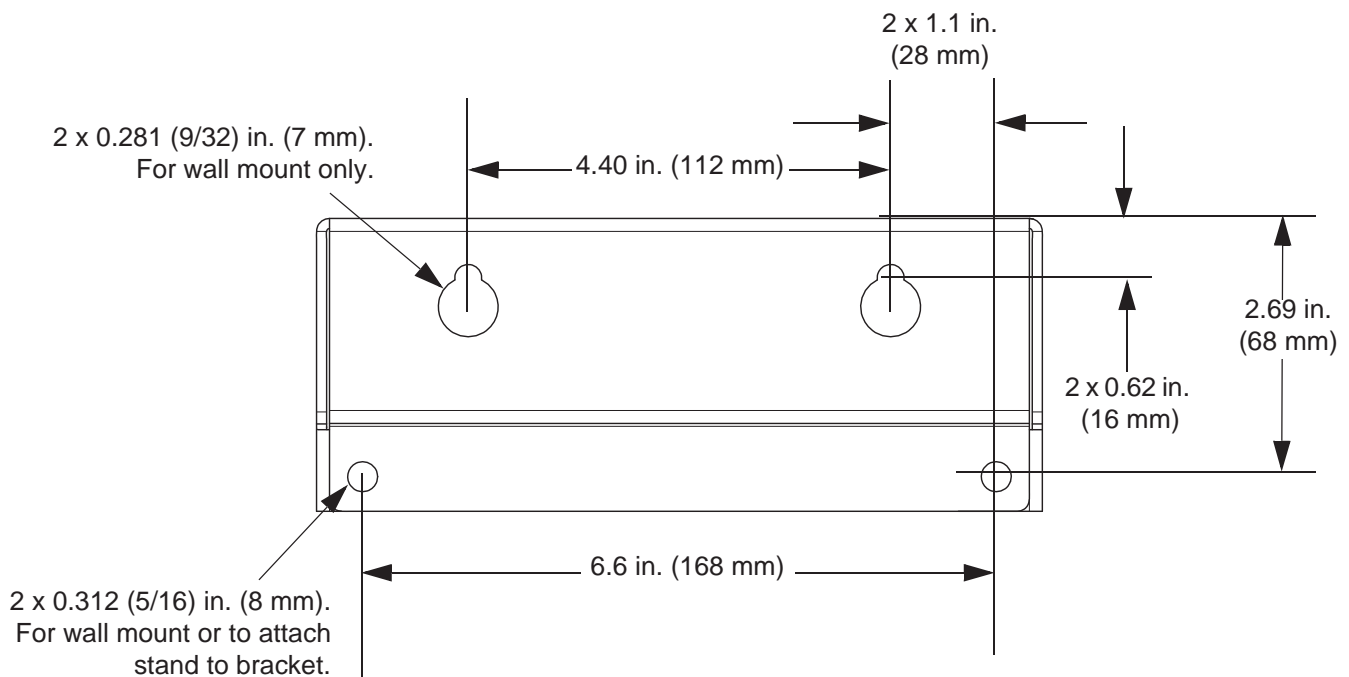

TI31938

Performance Charts

2.5 in. Motors

1/8 in. Plunger (PCI-250-13)

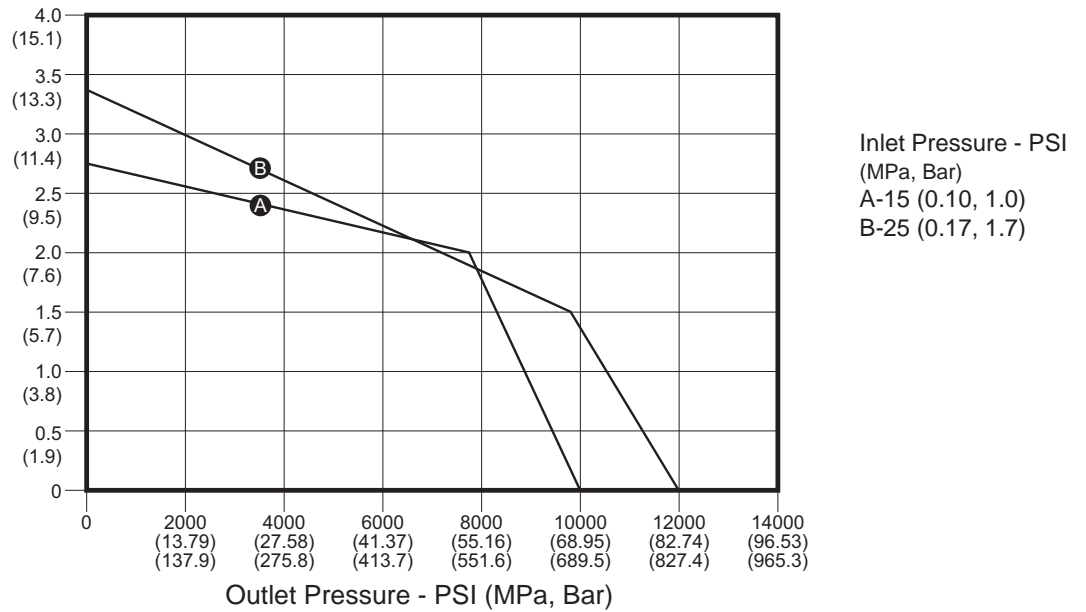

FIG. 25

3/16 in. Plunger (PCI-250-19)

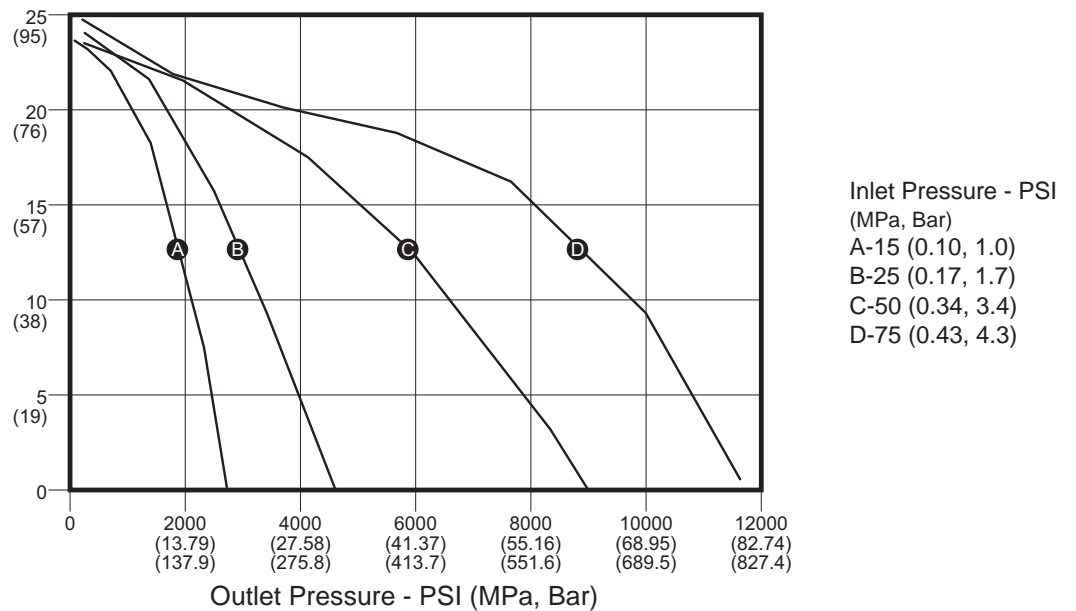

FIG. 26

1/4 in. Plunger (PCI-250-25)

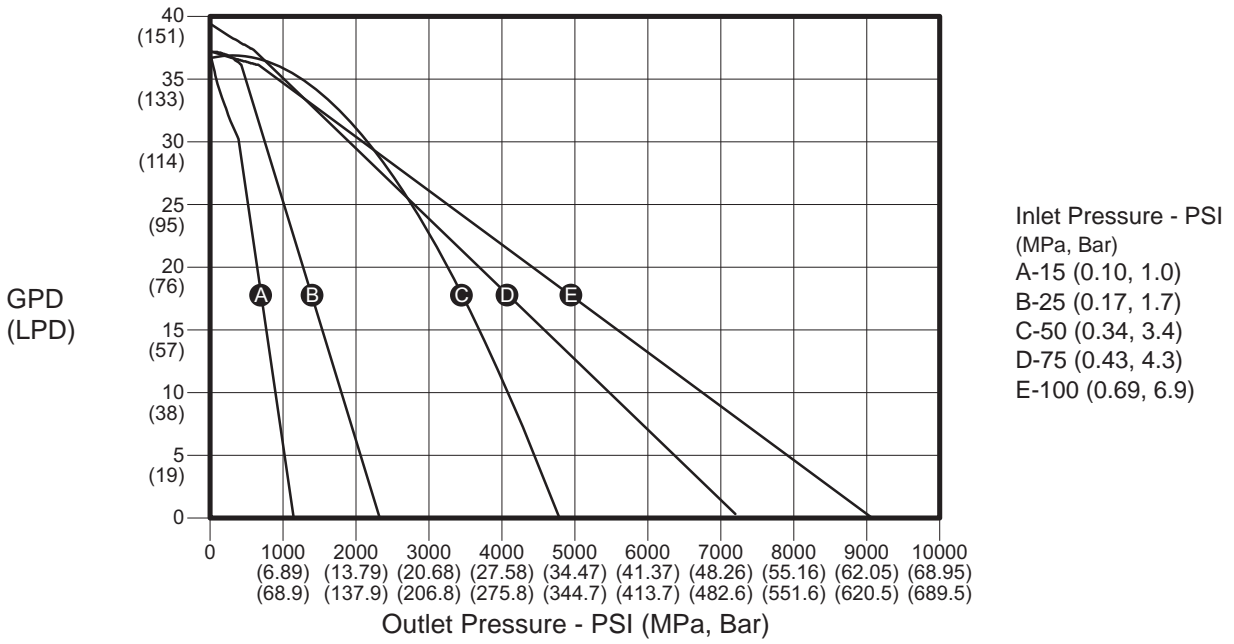

FIG. 27

3/8 in. Plunger (PCI-250-38)

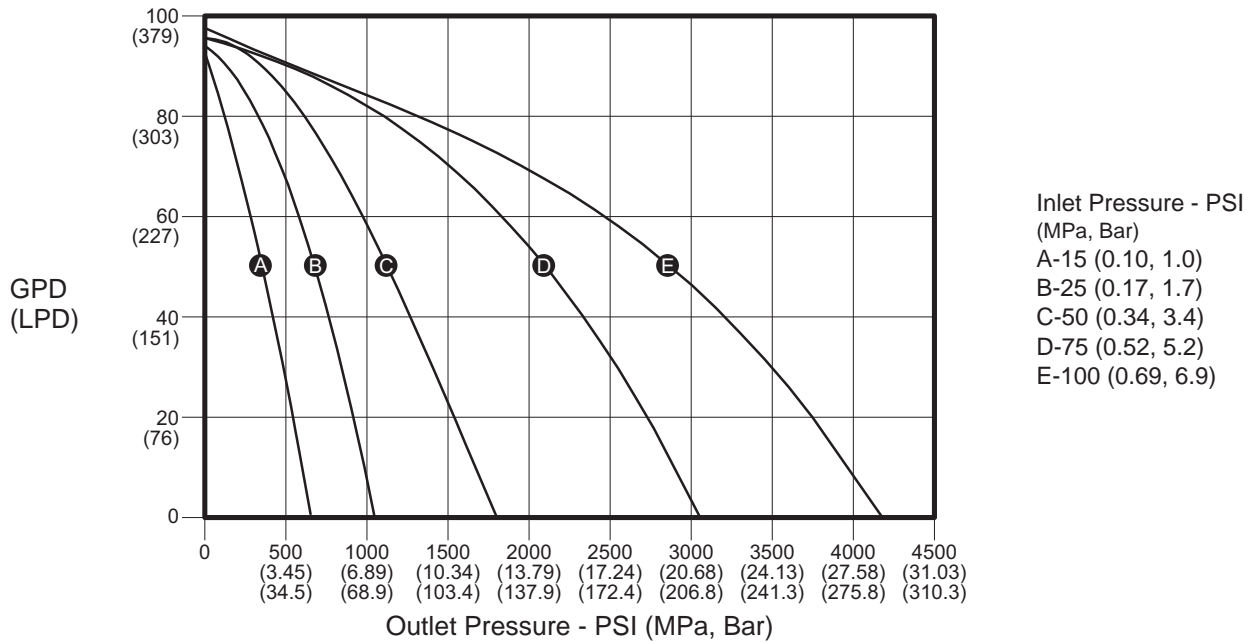

FIG. 28

1/2 in. Plunger (PCI-250-50)

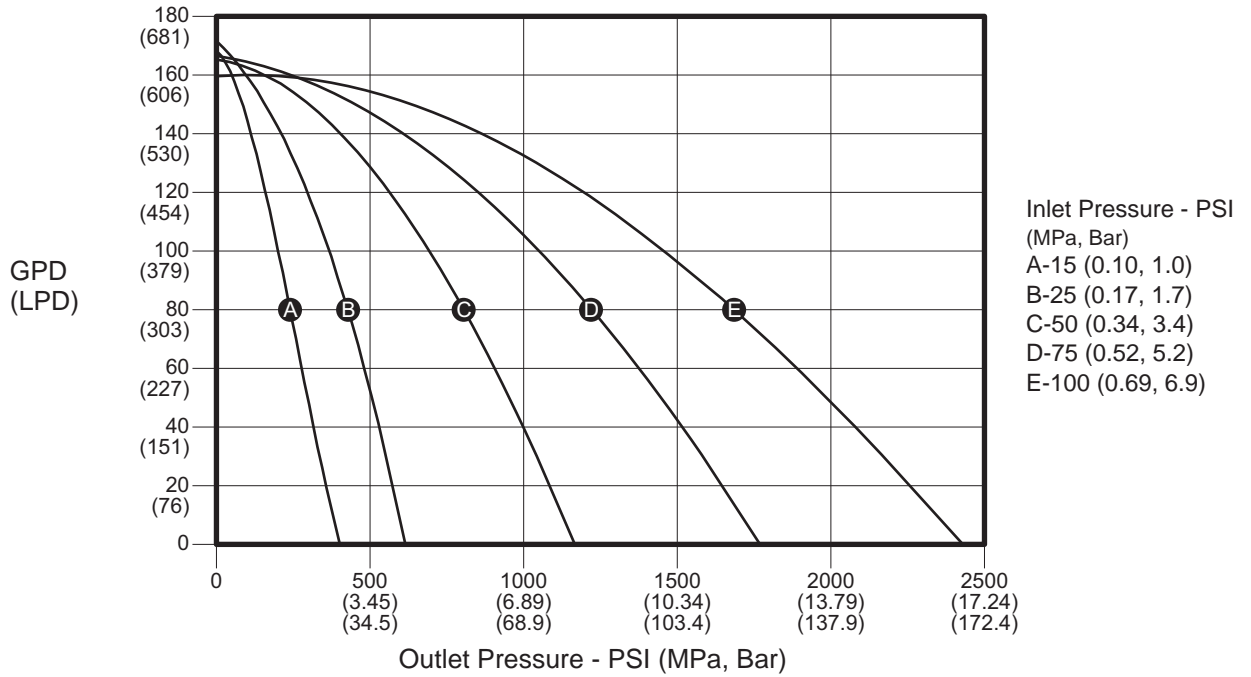

FIG. 29

5/8 in. Plunger (PCI-250-63)

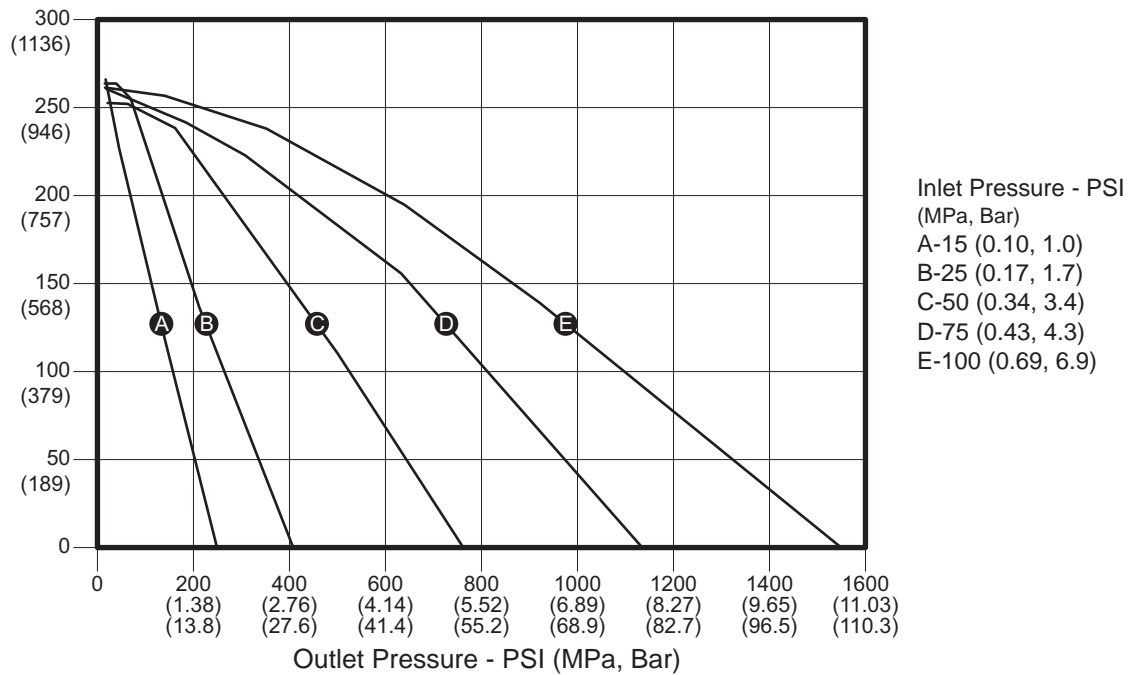

FIG. 30

3/4 in. Plunger (PCI-250-75)

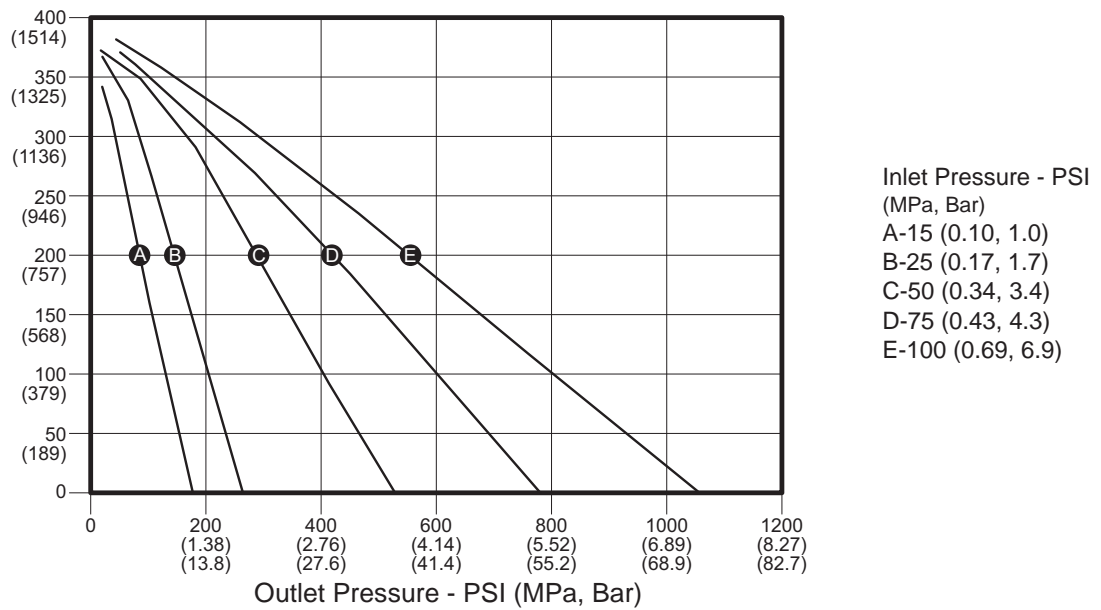

FIG. 31

3.5 in. Motors

1/4 in. Plunger (PCI-350-25)

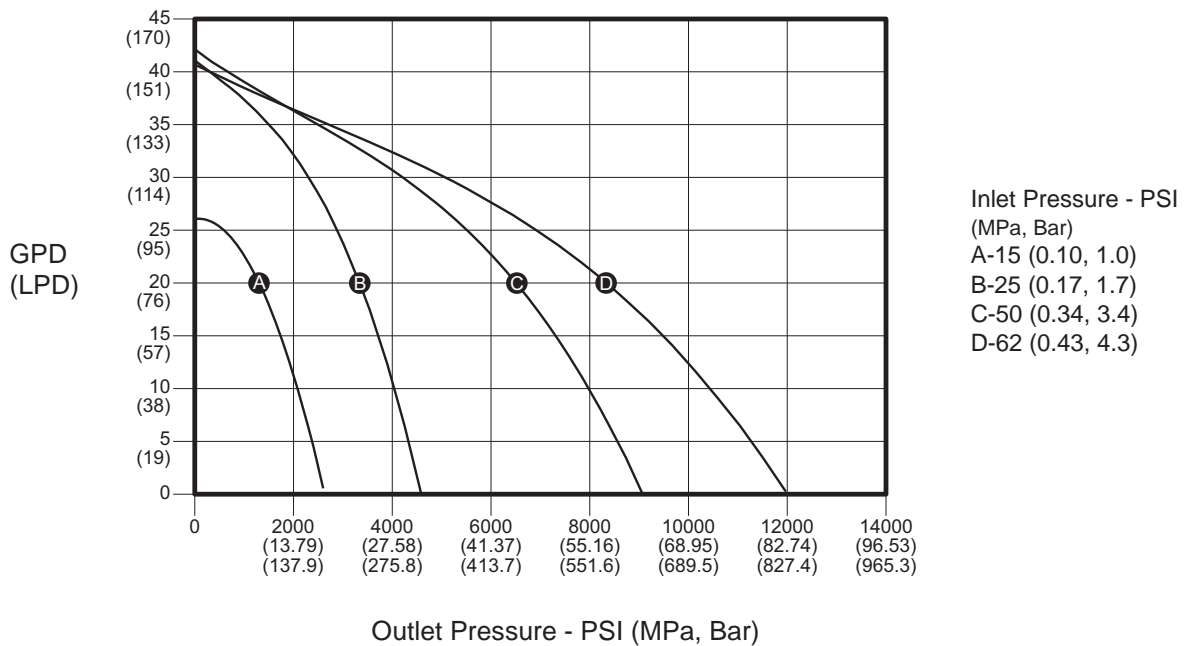

FIG. 32

3/8 in. Plunger (PCI-350-38)

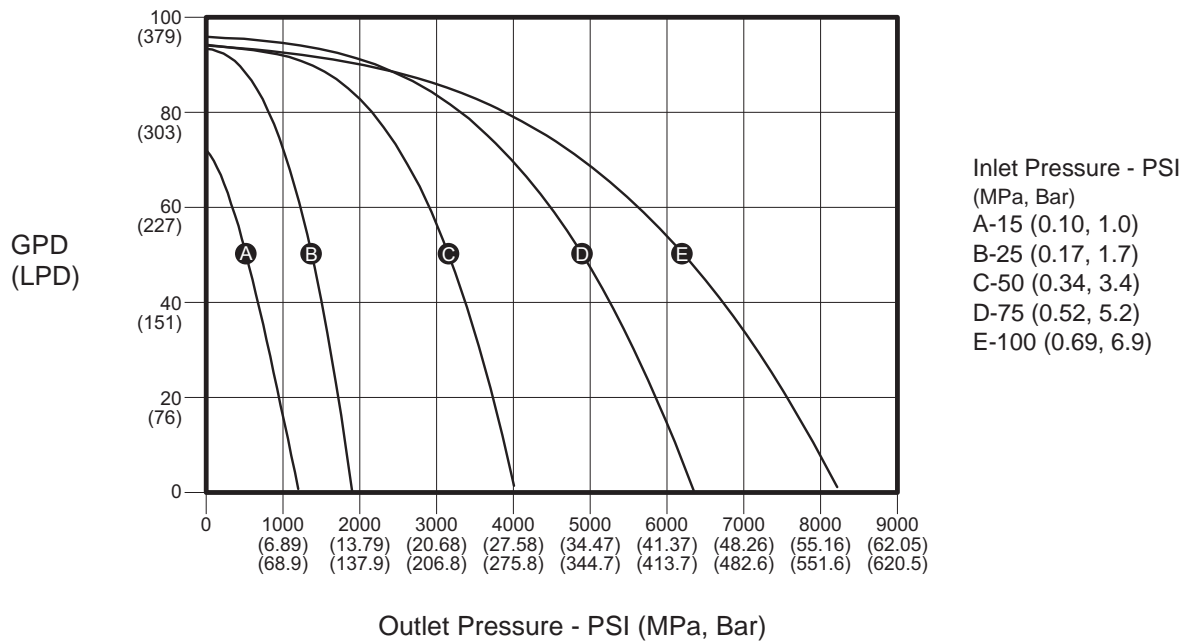

FIG. 33

1/2 in. Plunger (PCI-350-50)

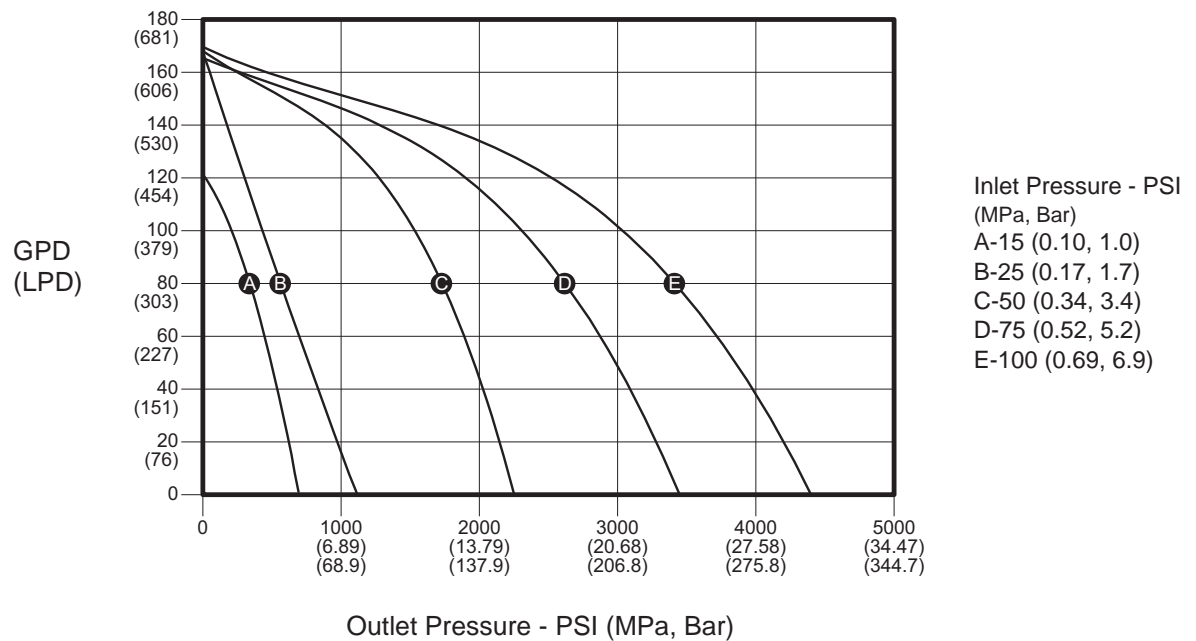

FIG. 34

5/8 in. Plunger (PCI-350-63)

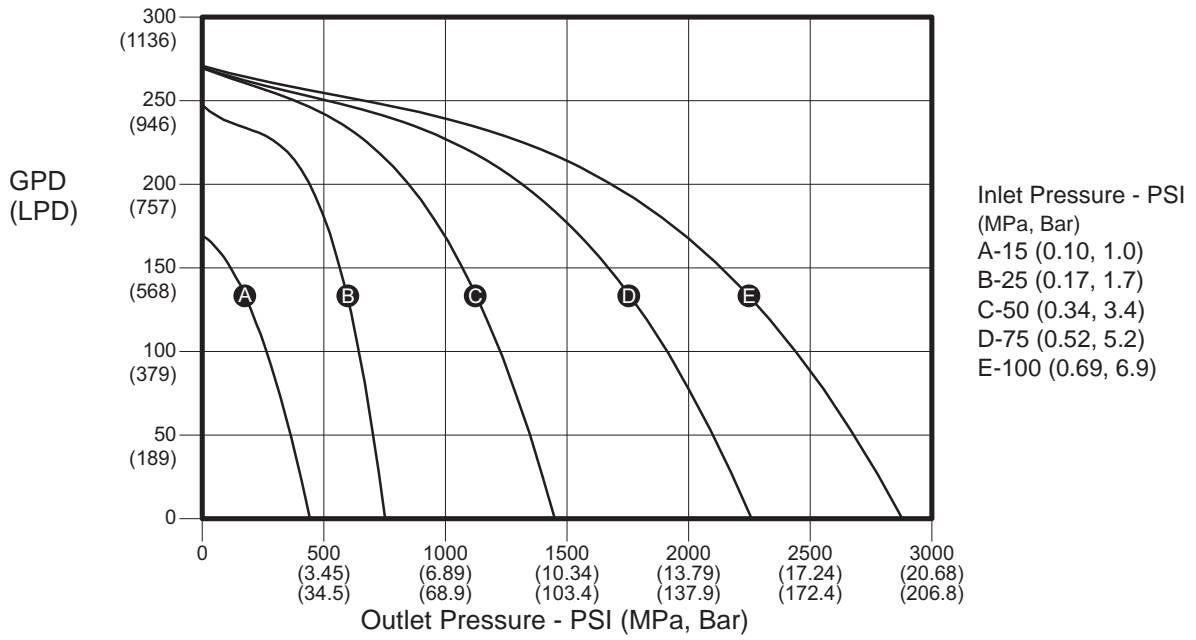

FIG. 35

3/4 in. Plunger (PCI-350-75)

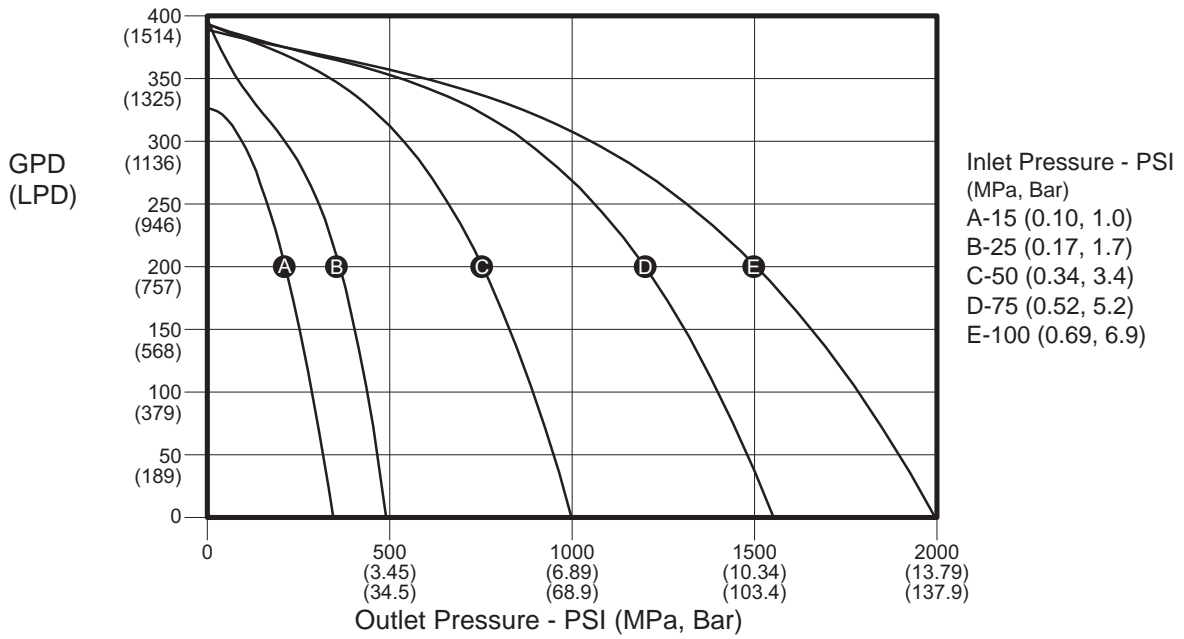

FIG. 36

4.5 in. Motors

1/4 in. Plunger (PCI-450-25)

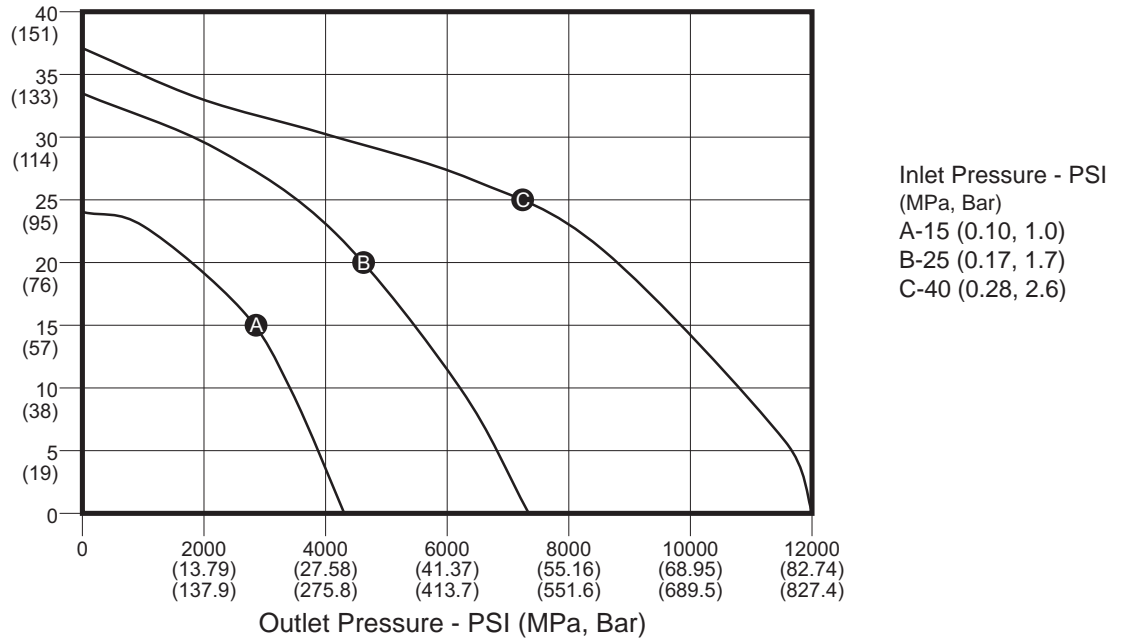

FIG. 37

3/8 in. Plunger (PCI-450-38)

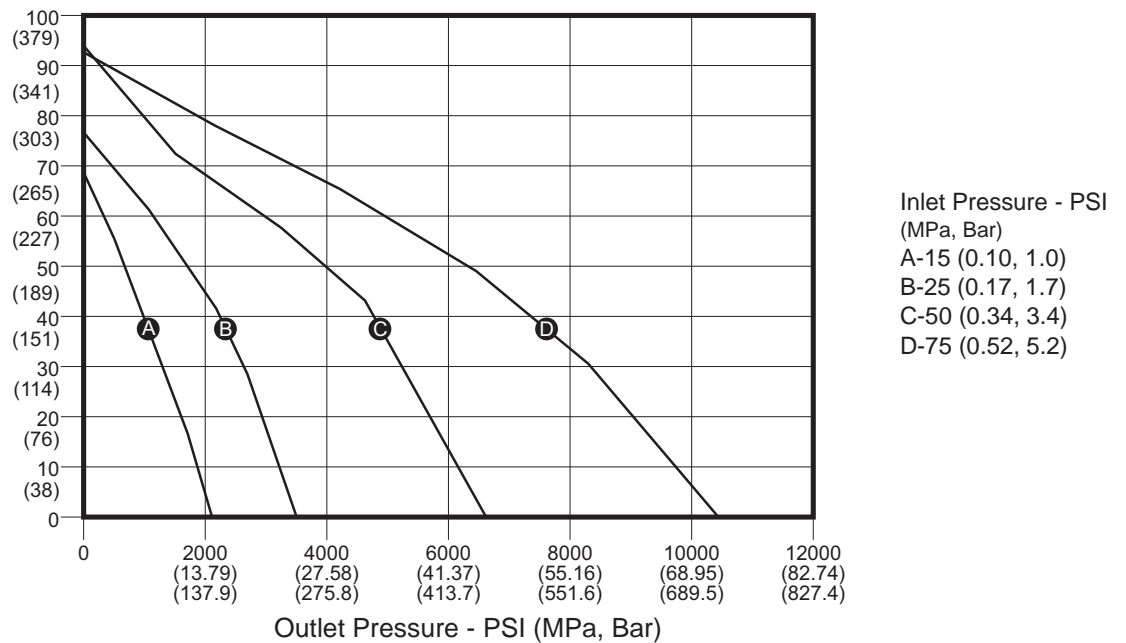

FIG. 38

1/2 in. Plunger (PCI-450-50)

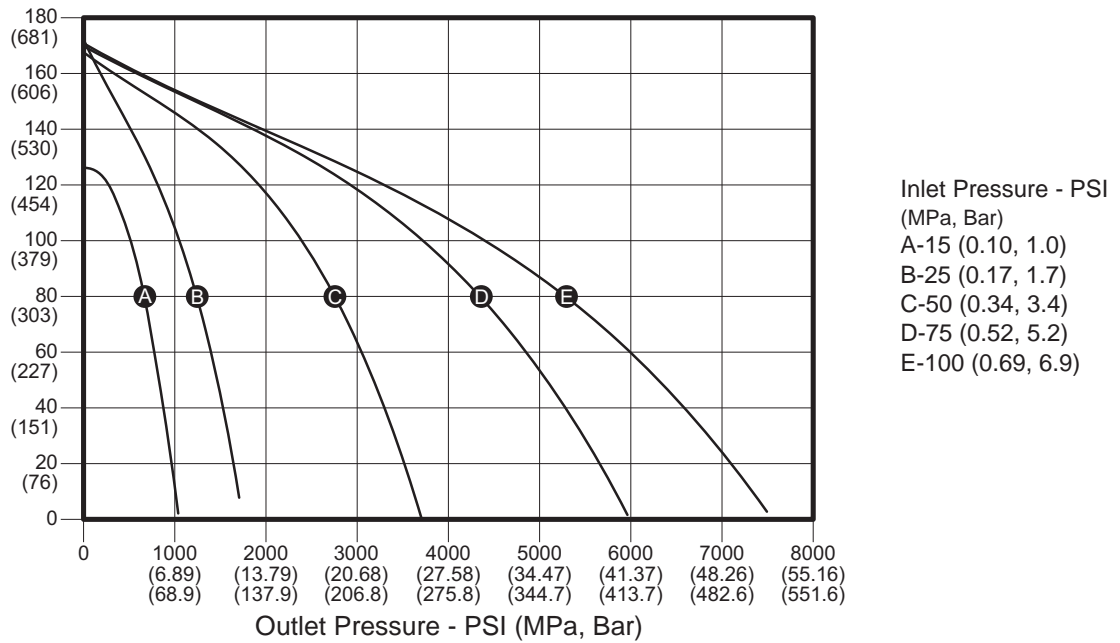

FIG. 39

5/8 in. Plunger (PCI-450-63)

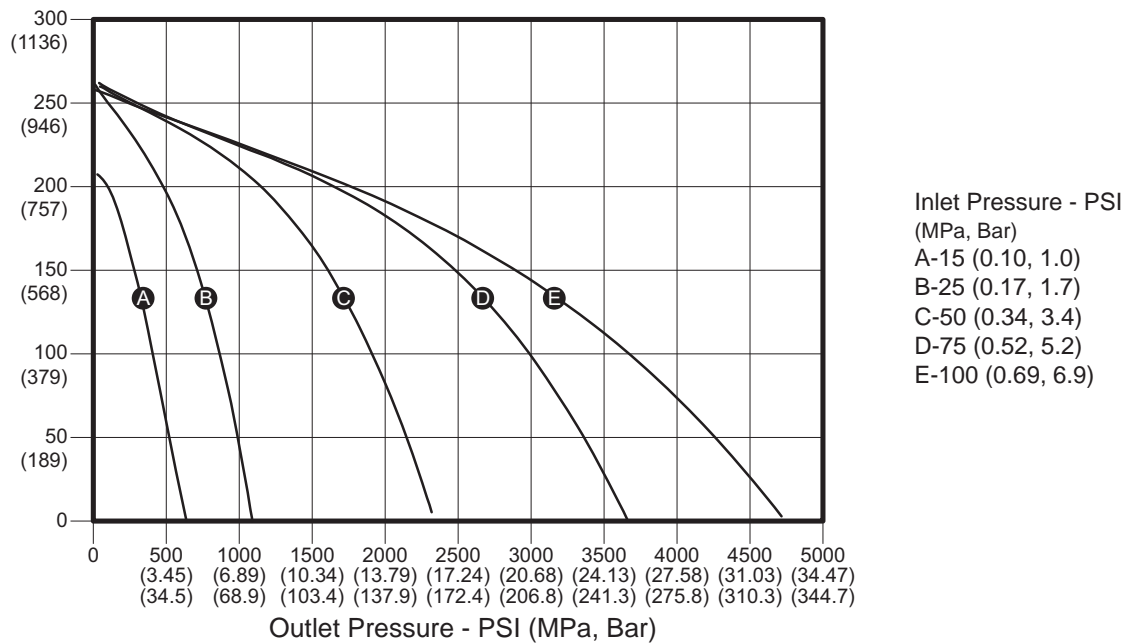

FIG. 40

3/4 in. Plunger (PCI-450-75)

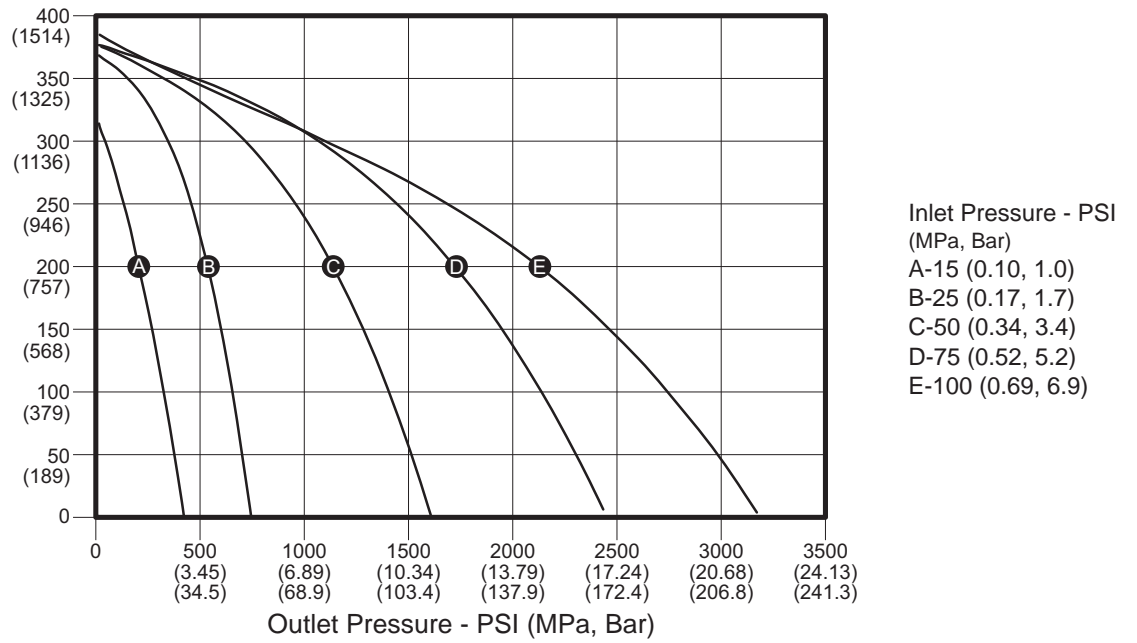

FIG. 41

Air/Gas Consumption

The air/gas consumption rate depends on the cycle rate of the pump. To estimate your cycle rate, see the **Baseline Chemical Dosage Settings**, page 16, and the **Performance Charts**, starting on page 43.

| 2.5 in. Motor | | | | | |
|----------------------------|-----------|-----------|------------|------------|-------------|
| Air or Gas Consumption | | | | | |
| SCFM (SM ³ /hr) | | | | | |
| CPM | 15 PSI | 25 PSI | 50 PSI | 75 PSI | 100 PSI |
| 10 | 0.3 (0.5) | 0.4 (0.4) | 0.6 (1.0) | 0.8 (1.4) | 1.1 (1.8) |
| 20 | 0.6 (0.9) | 0.7 (1.2) | 1.2 (2.3) | 1.7 (2.8) | 2.1 (3.6) |
| 30 | 0.8 (1.1) | 1.1 (1.9) | 1.8 (3.0) | 2.5 (4.2) | 3.2 (5.4) |
| 40 | 1.1 (1.9) | 1.5 (2.5) | 2.4 (4.1) | 3.3 (5.6) | 4.3 (7.2) |
| 50 | 1.4 (2.4) | 1.8 (3.1) | 3.0 (5.1) | 4.2 (7.1) | 5.3 (9.0) |
| 60 | 1.7 (2.8) | 2.2 (3.7) | 3.6 (6.1) | 5.0 (8.5) | 6.4 (10.9) |
| 70 | 1.9 (3.3) | 2.6 (4.3) | 4.2 (7.1) | 5.8 (9.9) | 7.5 (12.7) |
| 80 | 2.2 (3.8) | 2.9 (4.9) | 4.8 (8.1) | 6.7 (11.3) | 8.5 (14.5) |
| 90 | 2.5 (4.2) | 3.3 (5.7) | 5.4 (9.1) | 7.5 (12.7) | 9.6 (16.3) |
| 100 | 2.8 (4.7) | 3.6 (6.2) | 6.0 (10.2) | 8.3 (14.1) | 10.7 (18.1) |

| 3.5 in. Motor | | | | | |
|----------------------------|-----------|-----------|------------|------------|-------------|
| Air or Gas Consumption | | | | | |
| SCFM (SM ³ /hr) | | | | | |
| CPM | 15 PSI | 25 PSI | 50 PSI | 75 PSI | 100 PSI |
| 10 | 0.3 (0.5) | 0.4 (0.7) | 0.7 (1.2) | 1.0 (1.6) | 1.2 (2.1) |
| 20 | 0.6 (1.1) | 0.8 (1.4) | 1.4 (2.3) | 1.9 (3.3) | 2.5 (4.2) |
| 30 | 1.0 (1.6) | 1.3 (2.2) | 2.1 (3.5) | 2.9 (4.9) | 3.7 (6.3) |
| 40 | 1.3 (2.2) | 1.7 (2.9) | 2.8 (4.7) | 3.8 (6.5) | 4.9 (8.4) |
| 50 | 1.6 (2.7) | 2.1 (3.6) | 3.5 (5.9) | 4.8 (8.2) | 6.2 (10.4) |
| 60 | 1.9 (3.3) | 2.5 (4.2) | 4.1 (7.0) | 5.8 (9.8) | 7.4 (12.5) |
| 70 | 2.2 (3.8) | 2.9 (5.0) | 4.8 (8.2) | 6.7 (11.4) | 8.6 (14.6) |
| 80 | 2.6 (4.3) | 3.4 (5.7) | 5.5 (9.4) | 7.7 (13.0) | 9.8 (16.7) |
| 90 | 2.9 (4.9) | 3.8 (6.4) | 6.2 (10.6) | 8.6 (14.7) | 11.1 (18.8) |
| 100 | 3.2 (5.4) | 4.2 (7.1) | 6.9 (11.7) | 9.6 (16.3) | 12.3 (20.9) |

| 4.5 in. Motor | | | | | |
|----------------------------|-----------|------------|-------------|-------------|-------------|
| Air or Gas Consumption | | | | | |
| SCFM (SM ³ /hr) | | | | | |
| CPM | 15 PSI | 25 PSI | 50 PSI | 75 PSI | 100 PSI |
| 10 | 0.5 (0.9) | 0.7 (1.2) | 1.1 (1.9) | 1.6 (2.7) | 2.0 (3.5) |
| 20 | 1.1 (1.8) | 1.4 (2.4) | 2.3 (3.9) | 3.2 (5.4) | 4.1 (6.9) |
| 30 | 1.6 (2.7) | 2.1 (3.5) | 3.4 (5.8) | 4.8 (8.1) | 6.1 (10.4) |
| 40 | 2.1 (3.6) | 2.8 (4.7) | 4.6 (7.8) | 6.3 (10.8) | 8.1 (13.8) |
| 50 | 2.6 (4.5) | 3.5 (5.9) | 5.7 (9.7) | 7.9 (13.5) | 10.2 (17.3) |
| 60 | 3.2 (5.4) | 4.2 (7.1) | 6.8 (11.6) | 9.5 (16.2) | 12.2 (20.7) |
| 70 | 3.7 (6.3) | 4.9 (8.3) | 8.0 (13.6) | 11.1 (18.9) | 14.2 (24.2) |
| 80 | 4.2 (7.2) | 5.6 (9.4) | 9.1 (15.5) | 12.7 (21.6) | 16.3 (27.6) |
| 90 | 4.8 (8.1) | 6.2 (10.6) | 10.3 (17.4) | 14.3 (24.3) | 18.3 (31.1) |
| 100 | 5.3 (9.0) | 6.9 (11.8) | 11.4 (19.4) | 15.9 (27.0) | 20.3 (34.5) |

Technical Data

| Python XL Chemical Injection Pump | | |
|--------------------------------------------------------------------------|------------------------------------------------------------------------------------------------------------------------------------|-----------|
| | US | Metric |
| Maximum pneumatic inlet pressure | See Models on page 3. | |
| Maximum fluid working pressure | See Models on page 3. | |
| Maximum cycle rate | 100 cpm | |
| Environmental temperature range | -40°–176°F | -40°–80°C |
| Noise (dBa) | | |
| 2.5 in. Air Motor Sound Power* | 83.2 dBA | |
| 2.5 in. Air Motor Sound Pressure** | 76.5 dBA | |
| 3.5 in. Air Motor Sound Power* | 84.5 dBA | |
| 3.5 in. Air Motor Sound Pressure** | 77.9 dBA | |
| 4.5 in. Air Motor Sound Power* | 80.1 dBA | |
| 4.5 in. Air Motor Sound Pressure** | 70.2 dBA | |
| Inlet/Outlet Sizes | | |
| Fluid inlet size | 1/4 in. npt(f) | |
| Fluid outlet size (3/8 in., 1/2 in., 5/8 in., and 3/4 in. plungers only) | 1/4 in. npt(f) | |
| Fluid outlet size (1/4 in. plungers only) | HiP HF4 | |
| Prime/bleed size (3/8 in., 1/2 in., 5/8 in., and 3/4 in. plungers only) | 10-32 UNF | |
| Prime/bleed size (1/4 in. plungers only) | 1/16 in. npt(f) | |
| Pneumatic inlet size | 1/4 in. npt(f) | |
| Exhaust fitting size | 3/8 in. npt(f) | |
| Materials of Construction | | |
| Pump/Check Valve Seal Material | See Configuration Chart on page 4 for seal material. All other packing materials are PEEK and PTFE unless otherwise noted. | |
| Wetted Parts | See Configuration Chart on page 4 for plunger material. All other materials are 316 stainless steel unless otherwise noted. | |
| Weight | | |
| 2.5 in. (ALL MODELS) | 14.5 lbs. | 6.6 kg |
| 3.5 in. (ALL MODELS) | 20.0 lbs. | 9.1 kg |
| 4.5 in. (ALL MODELS) | 24.5 lbs. | 11.1 kg |

* Sound Power at 70 psi (0.48 MPa, 4.8 bar), 80 cpm. Sound power measured per ISO-9614-2.

** Sound Pressure was test 3.28 feet (1 m) from equipment.

Graco Standard Warranty

Graco warrants all equipment referenced in this document which is manufactured by Graco and bearing its name to be free from defects in material and workmanship on the date of sale to the original purchaser for use. With the exception of any special, extended, or limited warranty published by Graco, Graco will, for a period of twelve months from the date of sale, repair or replace any part of the equipment determined by Graco to be defective. This warranty applies only when the equipment is installed, operated and maintained in accordance with Graco's written recommendations.

This warranty does not cover, and Graco shall not be liable for general wear and tear, or any malfunction, damage or wear caused by faulty installation, misapplication, abrasion, corrosion, inadequate or improper maintenance, negligence, accident, tampering, or substitution of non-Graco component parts. Nor shall Graco be liable for malfunction, damage or wear caused by the incompatibility of Graco equipment with structures, accessories, equipment or materials not supplied by Graco, or the improper design, manufacture, installation, operation or maintenance of structures, accessories, equipment or materials not supplied by Graco.

This warranty is conditioned upon the prepaid return of the equipment claimed to be defective to an authorized Graco distributor for verification of the claimed defect. If the claimed defect is verified, Graco will repair or replace free of charge any defective parts. The equipment will be returned to the original purchaser transportation prepaid. If inspection of the equipment does not disclose any defect in material or workmanship, repairs will be made at a reasonable charge, which charges may include the costs of parts, labor, and transportation.

THIS WARRANTY IS EXCLUSIVE, AND IS IN LIEU OF ANY OTHER WARRANTIES, EXPRESS OR IMPLIED, INCLUDING BUT NOT LIMITED TO WARRANTY OF MERCHANTABILITY OR WARRANTY OF FITNESS FOR A PARTICULAR PURPOSE.

Graco's sole obligation and buyer's sole remedy for any breach of warranty shall be as set forth above. The buyer agrees that no other remedy (including, but not limited to, incidental or consequential damages for lost profits, lost sales, injury to person or property, or any other incidental or consequential loss) shall be available. Any action for breach of warranty must be brought within two (2) years of the date of sale.

GRACO MAKES NO WARRANTY, AND DISCLAIMS ALL IMPLIED WARRANTIES OF MERCHANTABILITY AND FITNESS FOR A PARTICULAR PURPOSE, IN CONNECTION WITH ACCESSORIES, EQUIPMENT, MATERIALS OR COMPONENTS SOLD BUT NOT MANUFACTURED BY GRACO. These items sold, but not manufactured by Graco (such as electric motors, switches, hose, etc.), are subject to the warranty, if any, of their manufacturer. Graco will provide purchaser with reasonable assistance in making any claim for breach of these warranties.

In no event will Graco be liable for indirect, incidental, special or consequential damages resulting from Graco supplying equipment hereunder, or the furnishing, performance, or use of any products or other goods sold hereto, whether due to a breach of contract, breach of warranty, the negligence of Graco, or otherwise.

FOR GRACO CANADA CUSTOMERS

The Parties acknowledge that they have required that the present document, as well as all documents, notices and legal proceedings entered into, given or instituted pursuant hereto or relating directly or indirectly hereto, be drawn up in English. Les parties reconnaissent avoir convenu que la rédaction du présente document sera en Anglais, ainsi que tous documents, avis et procédures judiciaires exécutés, donnés ou intentés, à la suite de ou en rapport, directement ou indirectement, avec les procédures concernées.

Graco Information

For the latest information about Graco products, visit www.graco.com.

For patent information, see www.graco.com/patents.

TO PLACE AN ORDER, contact your Graco distributor or call to identify the nearest distributor.

Phone: 612-623-6921 **or Toll Free:** 1-800-328-0211 **Fax:** 612-378-3505

*All written and visual data contained in this document reflects the latest product information available at the time of publication.
Graco reserves the right to make changes at any time without notice.*

Original instructions. This manual contains English. MM 3A3948

Graco Headquarters: Minneapolis

International Offices: Belgium, China, Japan, Korea

GRACO INC. AND SUBSIDIARIES • P.O. BOX 1441 • MINNEAPOLIS MN 55440-1441 • USA
Copyright 2015, Graco Inc. All Graco manufacturing locations are registered to ISO 9001.

www.graco.com

Revision H, July 2019